



**06TS,TT,TU,TV CARLYLE® PARAGON TWIN SCREW COMPRESSOR
APPLICATION GUIDE**



Contents

Introduction

R-134a Applications	3
R-404A, R-407A, R-407C, R-407F, R-507A Applications	3
Scope	3
Certifications	3
Compressor Offerings	3
Compressor Displacement (R-134a Models)	3
Compressor Displacement (Low/Medium Temperature Models)	4
Standard Features	4
Model Number Significance Chart	5
Compressor Physical Data and Connections	6-9

1.0 Medium/High Temperature System Design Considerations (R-134a)

1.1 Refrigerants and Lubricants	10
1.2 Environmental Considerations	10
1.3 Operating Limits and Controls	10-12
1.4 Control Points Summary	13

2.0 Medium/High Temperature System Oil Management (R-134a)

2.1 Oil Pressure Requirements	14
2.2 Oil Separator Recommendations	14
2.3 Oil Heater Recommendations for Air-Cooled Models	14
2.4 Oil Level Safety Switch	15
2.5 Oil Filter	15

3.0 Low/Medium Temperature System Design Considerations (R-404A, R-407A, R-407C, R-407F, R-507A)

3.1 Refrigerants and Lubricants	16
3.2 Environmental Considerations	16
3.3 Operating Limits and Controls	16-20
3.4 Control Points Summary	21

4.0 Low/Medium Temperature System Oil Management (R-404A, R-407A, R-407C, R-407F, R-507A)

4.1 Oil Pressure Requirements	22
4.2 Oil Separator Recommendations	22
4.3 Oil Heater Recommendations	22
4.4 Oil Level Safety Switch	22-23
4.5 Oil Filter	23

4.6 Oil Cooling Systems	23
4.7 Oil Cooler Selection	23
4.8 Oil Cooler Sizing	24-25

5.0 Unloader Operation

5.1 Unloader System Control Points	27
5.2 Approximate Part Load Factors	27
5.3 Slide Valve and Capacity Controller and Protection	28-35

6.0 Compressor Design Pressures

6.1 Compressor Requirements	36
6.2 Design Pressures	36

7.0 Variable Frequency Drive Guidelines

7.1 Scope	37
7.2 Capacity Control	37
7.3 Power Supply	37-38

8.0 Compressor Electrical Data

8.1 Allowable Voltage Range	39
8.2 Electrical Connection Requirements	39-40
8.3 Motor Data	41-47

9.0 Compressor Accessories

9.1 Oil Separators	48-49
9.2 Compressor Components Kit	50
9.3 Oil Accessories Kit	50
9.4 Compressor Protection Module Kit	51
9.5 Service Valves and Service Flanges	51
9.6 Unloader, Motor Cooling Valve, and Oil Solenoid Control Coils	52
9.7 Economizers	53
9.8 Motor Protection Devices	53
9.9 Oil Coolers/Liquid Injection Valves	54-57

10.0 Packaging and Storage Requirements

10.1 Packaging	58
10.2 Shipping	58
10.3 Storage	58
10.4 Weights and Dimensions	58
10.5 Compressor/Compact Oil Separator Assembly	59-62

Introduction

This manual is for the Carlyle® Paragon screw compressor product line, which is comprised of four unique compressor families (series type TS, TT, TU, and TV). Carlyle offers distinct versions of the Paragon Twin-Screw Compressors for Low/Medium/High Temperature applications. The operational limits, required accessories, and operational guidelines are contained in this manual and must be complied with to stay within the compressor warranty guidelines.

R-134a Applications

The TS series compressors are designed for air-cooled R-134a applications only. The TT, TU, and TV series compressors are available in both air-cooled and water-cooled versions for R-134a applications. There are 3 different displacement sizes of each of the TS, TT, and TV series compressors, along with 2 displacement sizes of the TU series compressor.

Each R-134a Paragon twin-screw compressor is designed to be applied with a dedicated, performance-matched oil separator. Carlyle offers two types of oil separators: high-efficiency (for applications in flooded-type systems) and standard-efficiency (for application in direct expansion-type systems). This compressor / oil separator assembly is then applied in a single-compressor, medium-temperature, or high-temperature refrigeration circuit. Carlyle offers the required oil separators as shown in Section 9.1 of this application guide. See Section 10.5 of this document for Assembly views of the R-134a Paragon models applied with these oil separator designs. Application guidelines for the R-134a compressors that have been approved for VFD applications are covered in this guide.

R-404A, R-407A, R-407C, R-407F, and R-507A Applications

The low/medium temperature Paragon twin-screw compressor models are designed to be applied in single or multiple compressor circuits. Each circuit requires a properly selected oil separator (contact Carlyle Application Engineering for selection criteria). Carlyle offers 3 models within each of the TS and TT compressor series for low/medium temperature applications.

Scope

This application guide is intended to familiarize system designers with the Paragon screw compressor and to

provide technical information necessary to assure safe and reliable compressor operation.

Certifications

UL and CSA approvals have been obtained for specific 06TS, 06TT, 06TU, and 06TV screw compressor models applied with R-134a and for certain 06TS and 06TT screw compressor models applied with R-404A, R-407A, R-407C, R-407F, and R-507A (compressors that have an R or M in the fifth digit of the model number).

UL File #: SA4936

CSA File #: SA4936

For the UL and CSA approvals it is essential that only Listed, Special-Purpose circuit breakers or Carlyle approved, solid-state motor overloads be used (contact Carlyle Application Engineering for further information). For circuit breakers, the Must Trip Amp settings must not exceed 140% of the compressor rated load amps.

Both UL and CSA approvals have been obtained for all voltage combinations shown in Section 8.3 of this guide. These compressor models also comply with the EC Low Voltage and Machinery Directives.

Compressor Offerings

The four Paragon compressor frame sizes (TS, TT, TU, and TV) are optimized for application in economized refrigeration circuits. Non-economized capacity will decrease by 11 to 16% for water-cooled operation. The following tables show the displacements for each of the compressors at 60 Hz.

Compressor Displacement (R-134a Models)

Table 1: Air-Cooled Models

MODEL NUMBER	NOMINAL HORSEPOWER	DISPLACEMENT (CFM at 60 Hz)
06TSA137	60	137
06TSA155	75	155
06TSA186	75	186
06TTA266	120	266
06TTA301	150	301
06TTA356	150	356
06TUA483	225	483
06TUA554	225	554
06TVA680	340	680
06TVA753	340	753
06TVA819	340	819

Table 2: Water-Cooled Models

MODEL NUMBER	NOMINAL HORSEPOWER	DISPLACEMENT (CFM at 60 Hz)
06TTW266	90	266
06TTW301	90	301
06TTW356	120	356
06TUW483	160	483
06TUW554	160	554
06TVW680	225	680
06TVW753	225	753
06TVW819	225	819

NOTE: Carlyle has optimized the Vi (volume index) for the R-134a air-cooled and water-cooled models.

Compressor Displacement (Low/Medium Temperature Models)

Table 3: Low Temperature (Refrigeration) Models

MODEL NUMBER	NOMINAL HORSEPOWER	DISPLACEMENT (CFM at 60 Hz)
06TSR137	60	137
06TSR155	75	155
06TSR186	75	186
06TTR266	120	266
06TTR301	150	301
06TTR356	150	356

Table 4: Medium Temperature Models

MODEL NUMBER	NOMINAL HORSEPOWER	DISPLACEMENT (CFM at 60 Hz)
06TSM137	75	137
06TSM155	75	155
06TTM266	150	266
06TTM301	150	301

Standard Features

See Fig. 1-4 for physical data and connection information.

Discharge Check Valve

The discharge check valve is an axial movement type located within the compressor. The check valve is field

serviceable by removing the oil separator or discharge line to access the valve in the compressor discharge housing.

Pressure Relief Valve

The Paragon screw compressors have an internal relief device, which is designed to relieve pressure from the high side to the low side of the compressor.

Suction and Economizer Screens

To increase the reliability of the compressor, a screen has been incorporated as a standard feature into the suction inlet and economizer inlet of the compressor. The suction inlet screen is installed into the suction inlet of each compressor. The economizer inlet screen is supplied in the economizer flange package (which is included in the compressor component kit, see Section 9.2 for details) and this screen must be installed by the OEM (Original Equipment Manufacturer). Please refer to the Economizer Flange Installation Instruction document for more details.

Slide Valve Unloading System

All Paragon screw compressors utilize a continuous slide valve unloading system. The slide valve decreases the compressor's capacity by reducing the amount of compression performed by the screw rotors. It is infinitely variable down to approximately 30% of full load capacity for air-cooled models and approximately 15% of the full load capacity for water-cooled models. These percentages of unloading are based on operation at typical rating conditions and may be different at other operating conditions.

Variable Speed for Capacity Control

Many of the R-134a air-cooled and water-cooled compressors have been qualified for operation with a variable frequency drive (VFD). In many applications it is possible to combine the use of variable speed and slide valve control to achieve superior compressor capacity control. Recommendations and requirements for these applications are provided in Section 7.0.

Model Number Significance Chart

DIGIT	1	2	3	4	5	6	7	8	9	10	11	12
MODEL NO.	0	6	T	T	A	3	5	6	S	S	1	C

1 st & 2 nd	DESIGN FEATURE
06	Semi-Hermetic

3 rd & 4 th	MODEL CODE
TS	Paragon
TT	Paragon
TU	Paragon
TV	Paragon

5 th	DESIGN VARIABLE
A	Air-Cooled Vi
R	Low Temperature Vi (Refrigeration)
W	Water-Cooled Vi
X	Variable-Speed (WC Vi)
M	Medium Temperature Vi

6 th , 7 th , & 8 th	
DISPLACEMENT (CFM at 60 Hz)	MODEL REF.
137	TS1
155	TS2
186	TS3
266	TT1
301	TT2
356	TT3
483	TU2
554	TU3
680	TV1
753	TV2
819	TV3

12 th	PACKAGE / ACCS.
A	Not Used
B	Not Used
C	Plate Mounting Feet
D	Bar Mounting Feet

11 th	DESIGN LEVEL
1	Phase 1
3	Product Variant
9	Not Used

10 th	MOTOR SIZE
G	60
J	75
M	90
P	120
S	150
T	160
W	225
X	340

LEGEND
 Vi — Volume Index
 WC — Water-Cooled
 VFD — Variable Frequency Drive

9 th	MOTOR VOLTAGES	
S	400/460-3-50/60	690-3-50 (Wye)
T	575-3-60	
W	380-3-60	690-3-60 (Wye)
X	200/230-3-50/60	
Z	200-3-60	

Compressor Physical Data and Connections

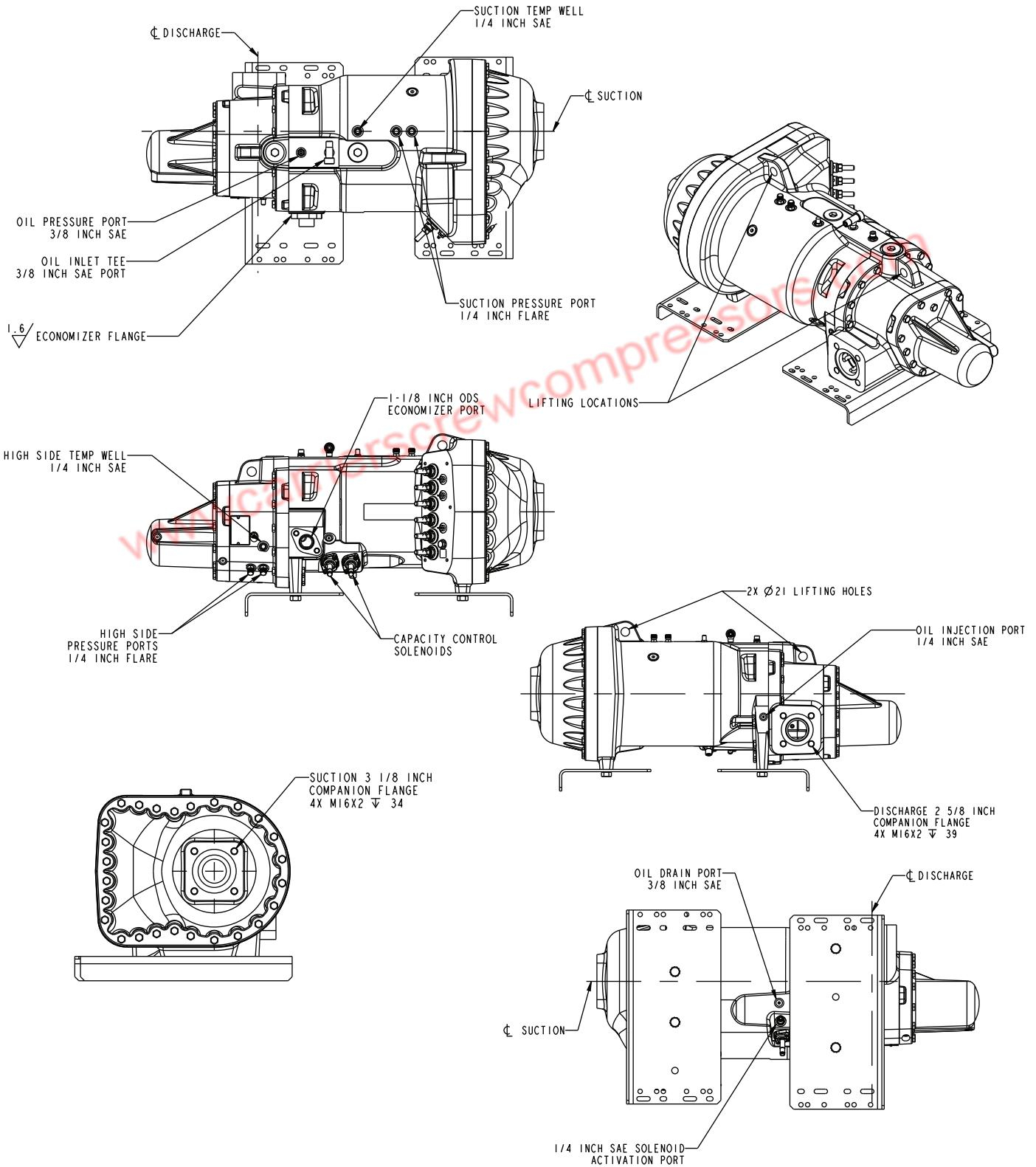

Fig. 1 — 06TS Compressor Physical Data and Connections

Compressor Physical Data and Connections (cont)

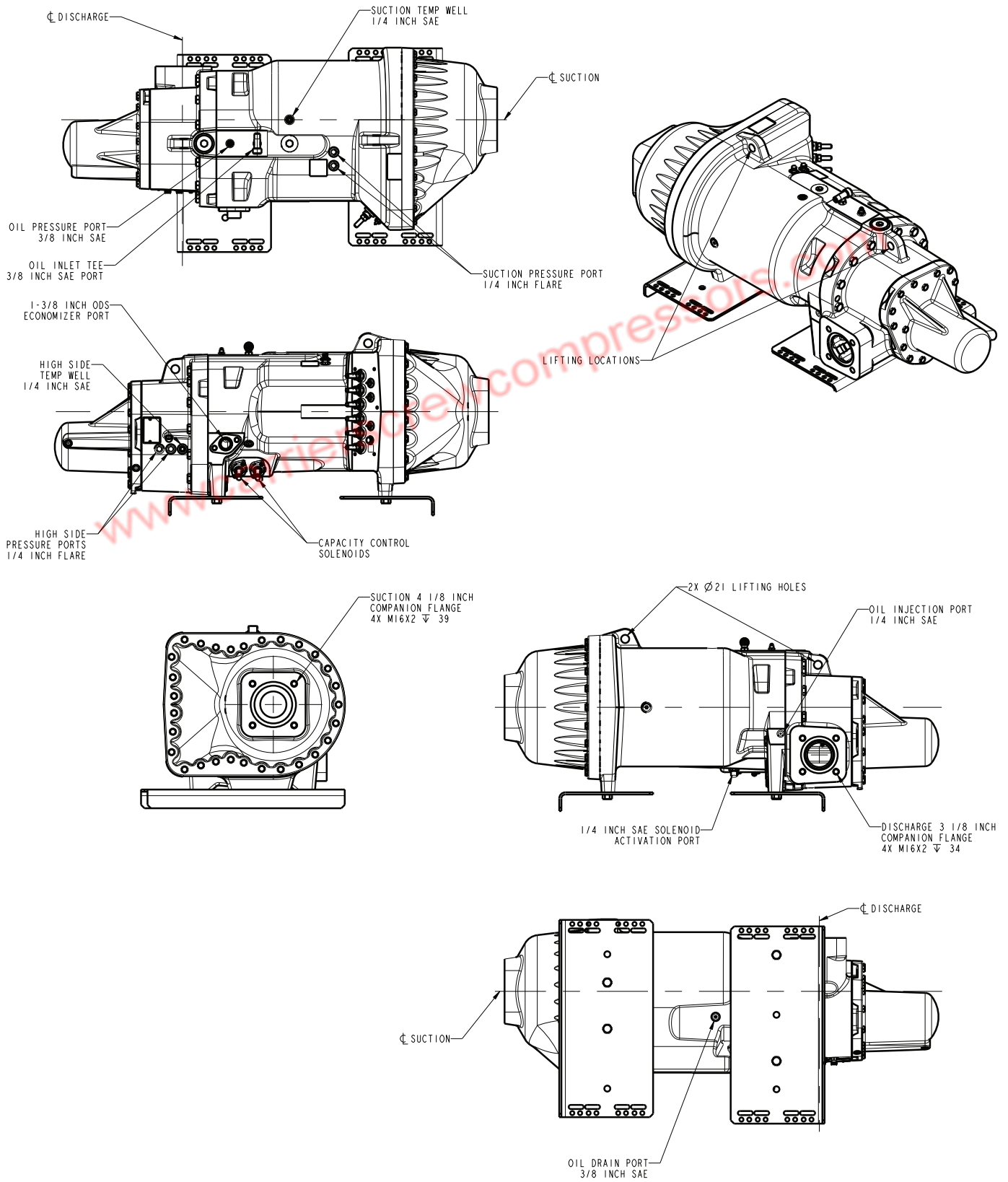

Fig. 2 — 06TT Compressor Physical Data and Connections

Compressor Physical Data and Connections (cont)

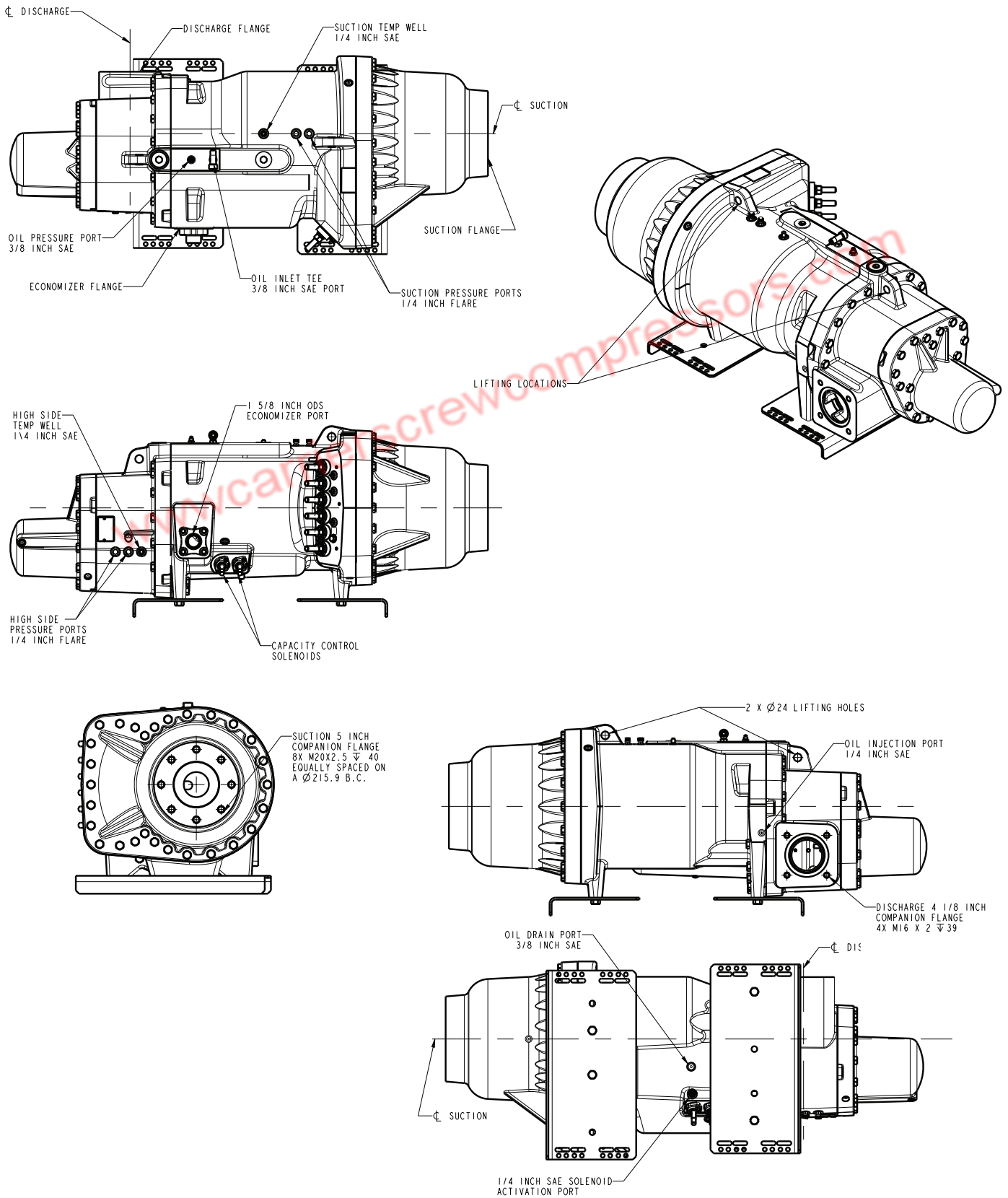

Fig. 3 — 06TU Compressor Physical Data and Connections

Compressor Physical Data and Connections (cont)

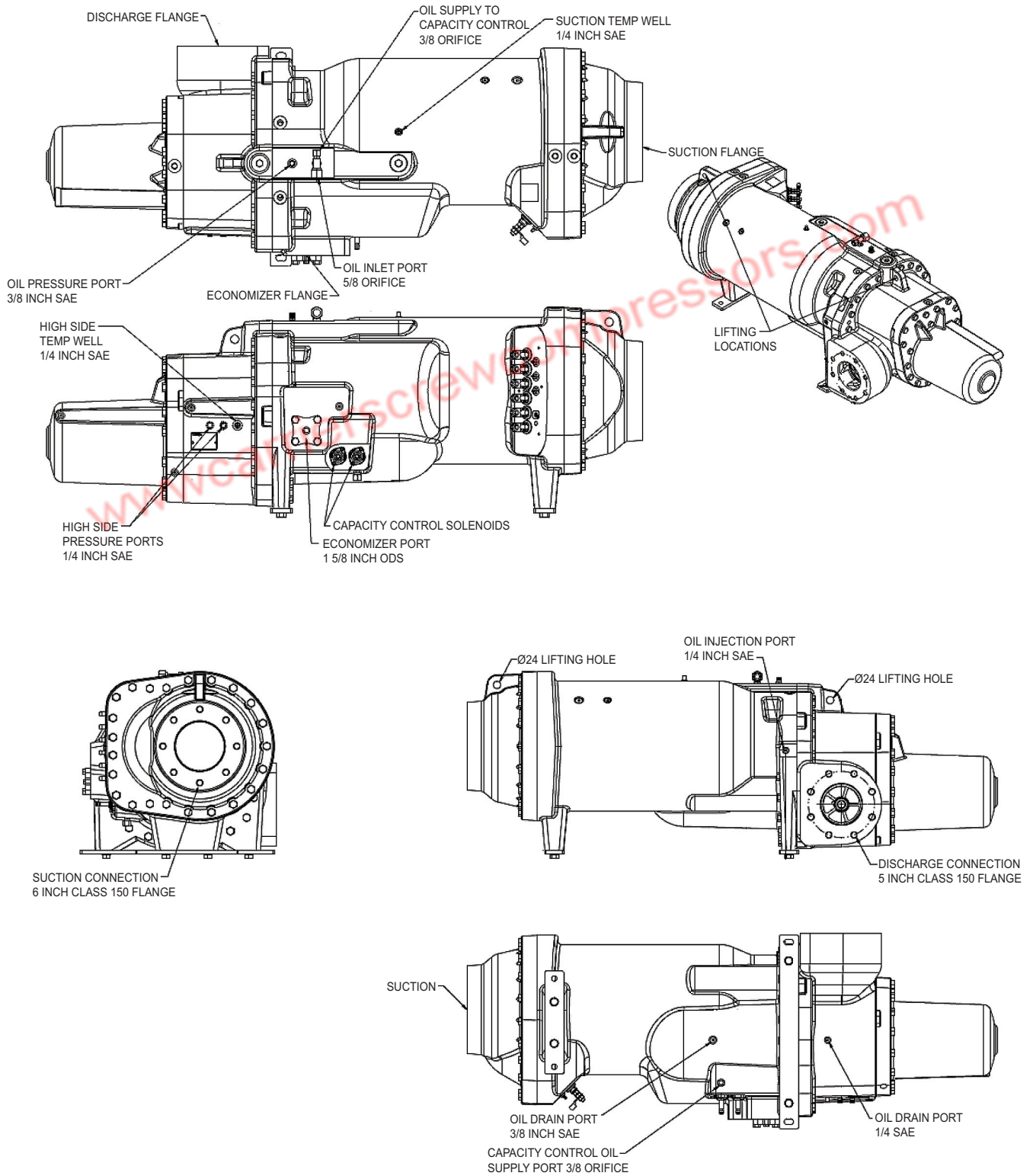

Fig. 4 — 06TV Compressor Physical Data and Connections

1.0 Medium/High Temperature System Design Considerations (R-134a)

1.1 Refrigerants and Lubricants

Approved Refrigerants

The Paragon medium-temperature screw compressor is specifically designed for use in R-134a systems.

Approved Lubricants

The Paragon screw compressor is approved for use with the following lubricants:

Approved Lubricant — Emkarate RL 220H

Viscosity Grade — ISO 220

or

Approved Lubricant — Emkarate RL 220HC

Viscosity Grade — ISO 220

Carrier Part Number — 1 gallon: P903-2301

5 gallon: P903-2305

Assembly Grease

On occasion, it may be necessary to use an assembly grease to retain an O-ring within its groove. The following assembly grease is approved for use with the Paragon screw compressor:

Approved Lubricant — Castrol Synplex GP2

or

Approved Lubricant — Parker Super-O-Lube

Carrier Part Number — 19XL680001

Terminal Pin Dielectric Grease

Carlyle recommends that compressor motor terminal pins are coated with dielectric grease (P/N 06TT660050)

to reduce the effects of condensation that may form on the terminal pins.

1.2 Environmental Considerations

Operating Ambient Temperature

The screw compressor is designed for the following ambient temperature ranges:

Non-Operating: -40 F to 176 F (-40 C to 80 C)

Operating: -31 F to 131 F (-35 C to 55 C)

Salt-Spray Requirements

The compressor has been tested through 500 hours of salt-spray in compliance with ASTM specification B-117.

1.3 Operating Limits and Controls

R-134a Operating Envelope

The following R-134a operating envelopes show where the compressor can be operated in both direct expansion and flooded applications. See Fig. 5 and Fig. 6. The envelopes differ for the unique design configuration of the compressor. The fifth digit of the model number indicates the operating envelope. The load line percentages refer to the capacity relative to full load at the same saturated suction temperature (SST) and saturated discharge temperature (SDT).

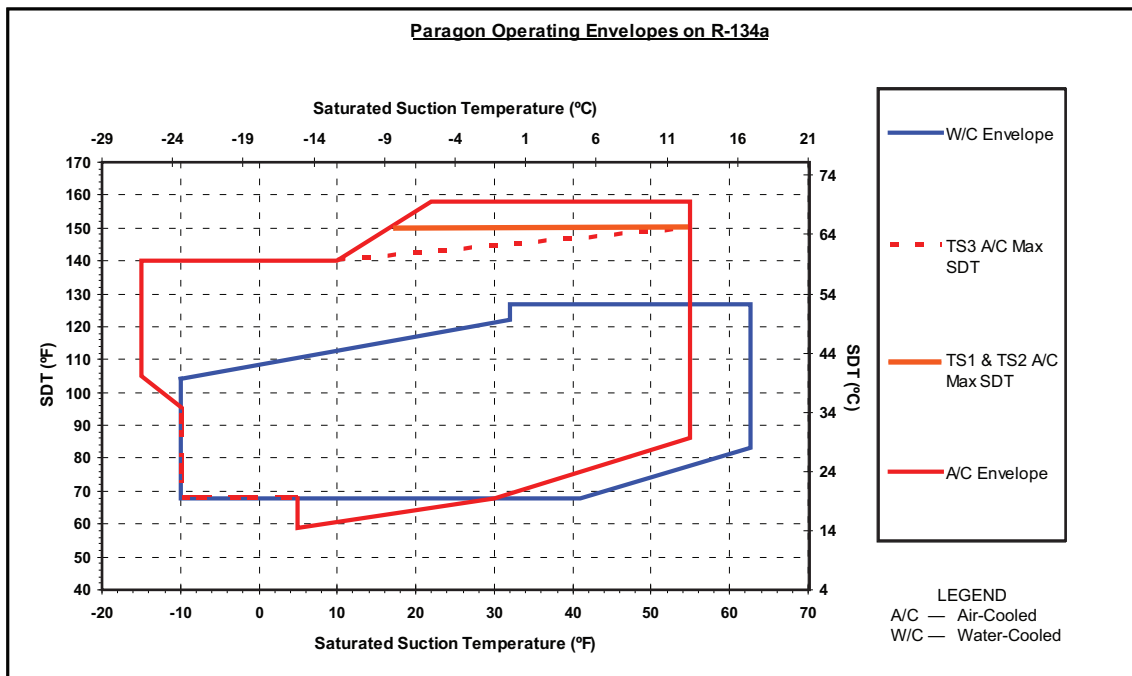
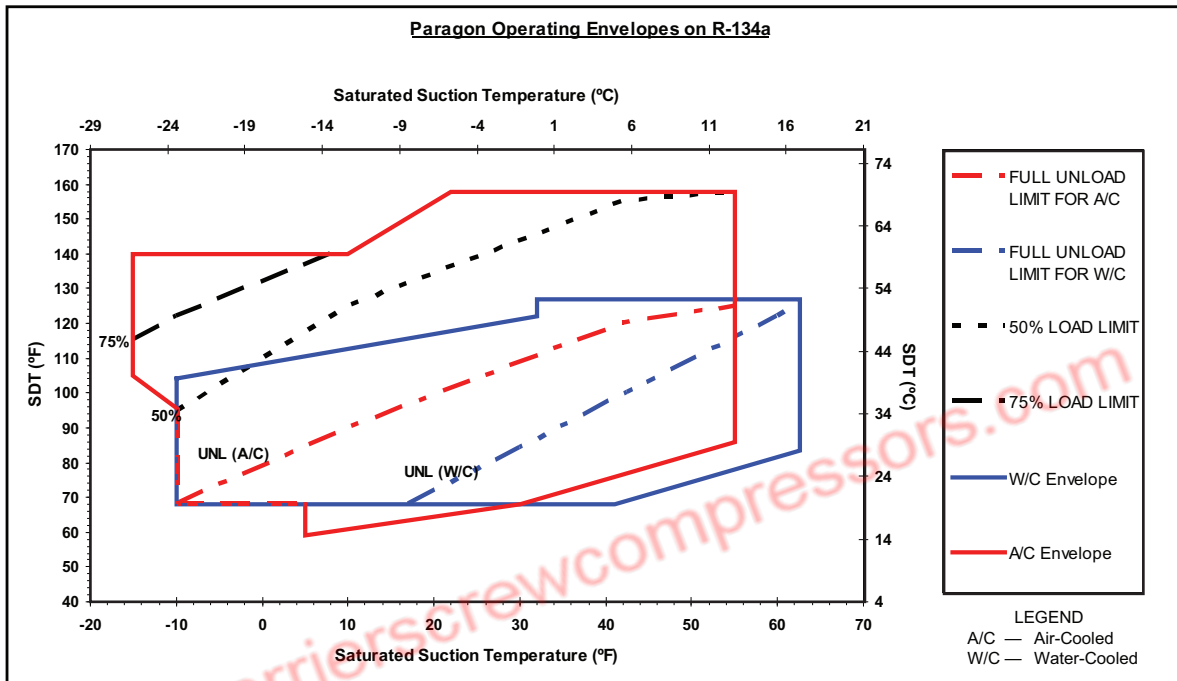

Fig. 5 — Operating Limits for Full Load Operation



NOTE: Liquid injection may be required when operating fully unloaded. Contact Carlyle Applications Engineering for valve sizing requirements.

Fig. 6 — Operating Limits for Unloaded Operation

Start-Up and Suction Pressure Transients

Operating a screw compressor without refrigerant flow through the compressor can be harmful. When this occurs, the evaporator typically will go into a vacuum, leading to very high pressure ratios and little mass flow to carry the heat away from the screw rotors. This situation most often occurs during start-up when the refrigerant may be in another part of the system. This is tolerable for short periods of time. The Paragon screw compressor should not be allowed to operate with a suction pressure less than 0 psig (vacuum) for more than 1 minute after a “cold” start. (Contact Carlyle Application Engineering for more information on cold starts.) If a compressor is allowed to operate for longer periods of time without refrigerant flow, catastrophic damage to the screw rotors, rotor housing, and discharge housing may occur, requiring compressor replacement.

Air-Cooled Oil Supply at Compressor

To reduce the possibility of liquid refrigerant becoming entrained in the oil, it is recommended that the temperature of the oil entering the compressor is kept above the outdoor ambient as shown in Fig. 7.

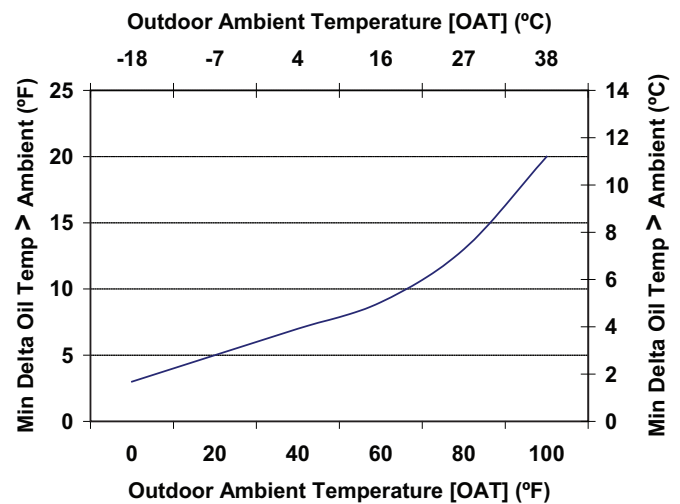

Fig. 7 — Oil Temperature

Temperature Limits

The following table shows the temperature range of control points allowable for the compressor using the approved lubricants listed in Section 1.1, Refrigerants and Lubricants.

Table 5: Allowable Temperature Ranges

CONTROL POINT	MINIMUM	MAXIMUM
Discharge Gas	20 F (11 C) superheat	210 F (99 C)
Economizer Gas	Saturated Liquid	9 F (5 C) superheat
Suction Gas	Saturated Vapor	Can float if motor and discharge maximum temps are met
Oil Supply at Compressor	Refer to Fig. 7	210 F (99 C)
Motor Windings	No limit	275 F (135 C)

Compressor Rotation Control

Correct compressor rotation is one of the most critical application considerations. Powered reverse rotation, even for a very short duration, can seriously affect the reliability of the compressor.

The reverse rotation protection scheme must be capable of determining the direction of rotation and stopping the compressor within 1 second.

Reverse rotation is most likely to occur at initial start-up or whenever the wiring to the compressor terminals is disturbed.

To minimize the possibility for reverse rotation operation, Carlyle recommends the following procedures:

1. During initial run test of the unit, a suitable low-pressure switch should be temporarily installed on the high-pressure port of the compressor and be wired to open the compressor control circuit. The purpose of this switch is to protect the compressor against any wiring errors at the compressor terminal pins. The electrical contacts of the switch must be wired in the control circuit of the compressor start components to shut off the compressor in the event it is operating in reverse rotation. This switch would remain in place for the duration of the run test. At the end of the run test the switch would be removed so that it could be used on the next unit or compressor to be tested.

2. For service replacement compressors, a similar protection system is recommended. The unit service literature will make reference to this switch and provide instructions on how to temporarily install the low-pressure switch into the safety circuit for the compressor. Each service compressor will be supplied with Installation Instructions documenting the procedure for installing and using the switch. The switch will remain in place until the compressor has been started and direction of rotation has been verified; at this point the switch will be removed.

The low-pressure switch must be suitable for the pressures consistent with R-134a systems, and the switch must be manually resettable and open when the pressure falls below 50 mm (2 inches) of vacuum. The switch is a manual reset type that can be reset after the pressure has once again risen above 1.7 bar (25 psia). It is critical that the switch be a manual reset type to preclude the compressor from short cycling in the reverse direction.

If a switch is not available, a manifold gage connected to the discharge housing of the compressor BEFORE THE DISCHARGE CHECK VALVE can be used. If the compressor can be “bumped” or “jogged” very quickly (< 1 second) while someone is watching the gage, compressor rotation can be determined without damage to the compressor. If the pressure drops, the compressor is rotating backwards and will have to be rewired. If the pressure goes up, the compressor is spinning in the correct direction.

Refrigeration System Design Considerations

In order to eliminate the possibility of refrigerant migrating into the oil separator and compressor, Carlyle requires the application of a positive-seal, discharge check valve (or a similar functioning device) to be installed in the discharge line after the oil separator.

Carlyle recommends the application of our qualified Safety Control Module package (P/N 6BSB000472), which provides the following safety control functionality:

- Discharge Temperature Monitoring
- Oil Level Monitoring (Optional)
- Reverse Rotation Monitoring
- Oil Flow-Rate/Supply Monitoring

Technical documentation for this Safety Control Module package (P/N 6BSB000472) is provided on the Carlyle website at www.carlylecompressor.com

1.4 Control Points Summary

<p>Reverse Rotation / Operation with Suction Pressure in Vacuum</p> <ul style="list-style-type: none"> Control must detect and prevent reverse rotation of the compressor within 1 second of compressor start-up. Compressor must not operate in a vacuum, as measured at the suction pressure port, for greater than 1 minute.
<p>Oil Pressure Confirmation / Safety</p> <ul style="list-style-type: none"> Three pressures must be observed to ensure that the oil pressure is suitable for compressor operation: suction, discharge, and oil. Oil pressure safety control must be manually reset. Oil pressure must be maintained as follows: <ol style="list-style-type: none"> $P_{OIL} > [0.7 \times (P_{DISCHARGE} - P_{SUCTION}) + P_{SUCTION}]$ $P_{OIL} > [P_{SUCTION} + 0.5 \text{ bar}]$ 15 seconds after start (Air-cooled models; <i>A</i> in 5th digit of model numbers) $[P_{SUCTION} + 1.0 \text{ bar}]$ 45 seconds after start (Refrigeration models; <i>R</i> in 5th digit of model numbers) $[P_{SUCTION} + 1.0 \text{ bar}]$ 75 seconds after start (Water-cooled models: <i>W</i> in 5th digit of model numbers)
<p>Oil Supply Confirmation / Oil Level Switch</p> <ul style="list-style-type: none"> Oil supply to the compressor must be maintained during operation at all times. Compressor operation must be stopped if the required oil level switch is open for 5 continuous seconds. Oil supply solenoid valve must be closed during OFF cycles.
<p>Oil Filter Differential Pressure</p> <ul style="list-style-type: none"> Compressor operation must be stopped if the pressure differential measured between the entering and leaving oil filter locations exceeds 2 bar. The oil filter supply tubing design should apply valves to allow for the isolation and replacement of the filter without removing the system refrigerant charge.
<p>Motor Temperature Limitation</p> <ul style="list-style-type: none"> Motor temperatures must be continuously monitored during compressor operation. Motor temperatures must not exceed 275 F (135 C).
<p>Compressor Short Cycling</p> <ul style="list-style-type: none"> Control must provide for a 10-minute minimum time delay before restarting the Paragon compressor. The maximum number of compressor START cycles per hour is 6.
<p>Maximum Discharge Gas Temperature</p> <ul style="list-style-type: none"> Discharge gas temperatures must not exceed 210 F (99 C). Control must prevent compressor operation when discharge gas temperatures exceed this maximum.
<p>Maximum Oil Temperature</p> <ul style="list-style-type: none"> Oil temperatures must not exceed 210 F (99 C). Control must prevent compressor operation when oil temperatures exceed this maximum.
<p>Run-Proof</p> <ul style="list-style-type: none"> Current must be monitored to detect welded contacts on a contactor or single-phase condition. Oil flow must be resumed if a contactor is determined to be welded shut. Compressor must be shut down if a single-phase condition is detected.
<p>Liquid Line Solenoid / Economizer</p> <ul style="list-style-type: none"> A liquid line solenoid valve is required to shut off liquid flow to the compressor during OFF cycles. Controlling this valve allows for additional capacity reduction during low load conditions.
<p>Unloading Control</p> <ul style="list-style-type: none"> Control must be provided to the two unloader coils. These coils position the slide valve mechanism within the compressor and allow for infinite unloading valve positioning.
<p>Unloaded Shutdown</p> <ul style="list-style-type: none"> It is recommended that the compressor operate for 30 seconds fully unloaded prior to shut down. This ensures fully unloaded re-start will occur.

NOTE: Carlyle offers Compressor Protection Module package P/N 6BSB000472, which protects against reverse rotation, low oil flow, and maximum discharge gas temperature. See Marketing Bulletin 14M-01 at www.carlylecompressor.com.

2.0 Medium/High Temperature System Oil Management (R-134a)

Oil supply system components are shown in Fig. 8.

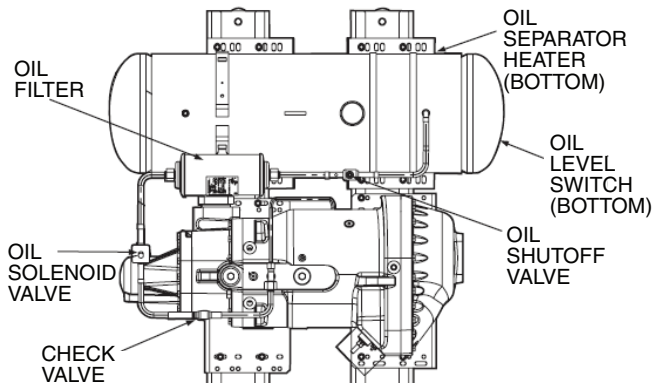

Fig. 8 — Oil Supply System Components

2.1 Oil Pressure Requirements — R-134a Systems

System pressure is used to generate the oil pressure required to lubricate bearings and provide the oil that acts as a seal between the screw rotors and the bores. Oil pressure is monitored continuously during compressor operation. The oil pressure must meet the following criteria, based on $P_{DISCHARGE}$, $P_{SUCTION}$, and P_{OIL} , as shown in Fig. 9:

1. $P_{OIL} > [0.7 \times (P_{DISCHARGE} - P_{SUCTION}) + P_{SUCTION}]$
2. $P_{OIL} > [P_{SUCTION} + 0.5 \text{ bar}]$ 15 seconds after start
 $[P_{SUCTION} + 1.0 \text{ bar}]$ 45 seconds after start
 (Air-cooled models; A in fifth digit of model number)
 $[P_{SUCTION} + 1.0 \text{ bar}]$ 75 seconds after start
 (Water-cooled models; W in 5th digit of model number)

The unit control system must monitor the oil pressure differential, as well as the operating condition, so the compressor can be shut down if the minimum requirements are not met for any duration exceeding 15 seconds.

This time delay has two functions: first, to avoid nuisance tripping during normal and transient operation, and second, to allow the system sufficient time to develop pressure differential during start-up.

The compressor must be shut down and prevented from restarting when the low oil pressure safety is tripped. The safety should be a manual reset type that locks out compressor operation until the system is serviced.

Carlyle offers a Compressor Protection Module package to provide protection against loss of oil flow, reverse-rotation, and elevated discharge gas temperature. Application of this package provides equal alternate protection to the method described above. The Carlyle R-134a

Compressor Protection Module package part number is 6BSB000472.

2.2 Oil Separator Recommendations

The Paragon compressor requires an oil separator. The combined oil capacity of the oil separator sump, the oil reservoir, and the oil cooler, should be greater than the values shown in Table 6.

The separator should be selected to provide a maximum oil carryover leaving the separator required by that system/application. Approximate oil flow versus compressor pressure differential (Discharge Pressure - Suction Pressure) is shown in Fig. 9. Additional oil charge may be required for systems that have longer tubing sets. See Sections 9.1.1, 9.1.2, and 10.5 for additional information.

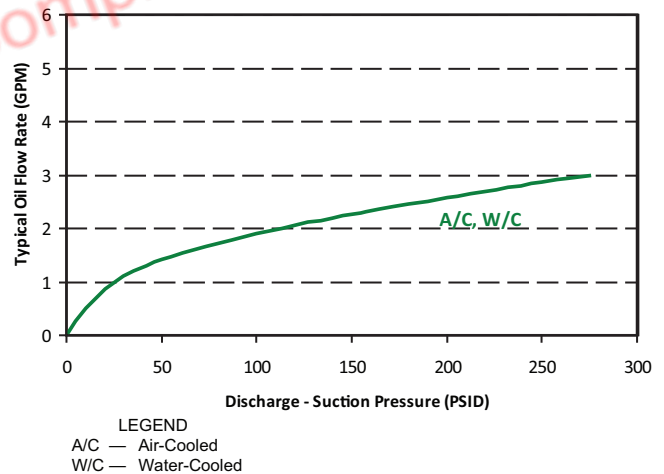

Fig. 9 — Oil Supply at Compressor

2.3 Oil Heater Recommendations for Air-Cooled Models

For the typical oil separators used with the Paragon compressor (see Table 6), a 500-watt flexible strip heater is recommended. The heater should be wired to operate when the compressor is OFF. This minimizes the migration of refrigerant to the oil stored in the sump. Figure 7 shows the minimum oil temperatures that must be maintained when the compressor is not operating based on the outdoor ambient temperature (OAT). If the application will allow refrigerant to collect in the compressor, then a heater must be installed on the compressor. Running unit water that is at least 20 F (11 C) below OAT, if possible, can be used to prevent refrigerant from collecting in the compressor. Carlyle recommends that the oil temperature be monitored in warm climate applications and that the oil separator heater be cycled off if oil temperatures reach 190 F (88 C).

Table 6: Oil Separators

	PART NUMBER	MINIMUM OIL CHARGE	DISCHARGE CFM
SIDE-MOUNT HORIZONTAL OIL SEPARATORS	8BSB000704	4.5 gal. (17.0 L)	17-150
	8BTB000705	4.5 gal. (17.0 L)	17-170
	8BVB000787	8.5 gal. (32.0 L)	15-150
COMPACT OVER / UNDER OIL SEPARATORS	8BSB000643	4.5 gal. (17.0 L)	17-170
	8BTB000644	4.5 gal. (17.0 L)	17-170
VERTICAL OIL SEPARATORS	KH31ZZ212	10 gal. (38.0 L)	30-60
	KH31ZZ420	10 gal. (38.0 L)	61-94
	KH31HZ381	3 gal. (11.4 L)	27-90
	KH31HZ382	8 gal. (30.3 L)	40-118
	KH31HZ421	8 gal. (30.3 L)	45-148
	KH31HZ428	5 gal. (19 L)	35-118

2.4 Oil Level Safety Switch

An oil level safety switch must be installed in the sump of the oil separator or the oil reservoir, depending on the system design. Carlyle recommends an oil level safety switch that interrupts compressor operation if oil levels are below adequate levels. Enough oil should remain in the sump when the switch is opened for the compressor to operate for at least one minute before completely running out of oil.

To reduce the possibility of false oil level alarms, Carlyle recommends that the oil level safety switch should be open continuously for 5 seconds prior to initiating compressor shutdown.

2.5 Oil Filter

Provisions should be made to isolate the oil filter using some combination of shutoff valves and/or check valves. This will allow for the filter element to be replaced without removing or isolating the charge in the unit.

Because of the long bearing life requirements, filtration for this compressor is very stringent. The Beta Ratio for this filter is greater than or equal to 200 for a five micron particle size evaluated using ISO 16889 ($\beta_{(5)} \geq 200$). Filter areas must also be sufficient to avoid premature clogging of the filter during normal operation. The Carlyle supplied filters have a filtration area of $> 5000 \text{ cm}^2$. An alarm in the controls should be signaled any time the pressure drop across the filter ($P_{\text{DISCHARGE}} - P_{\text{OIL}}$) exceeds 2 bar (29 psid), indicating the filter needs to be replaced.

3.0 Low/Medium Temperature System Design Considerations (R-404A, R-407A, R-407C, R-407F, R-507A)

3.1 Refrigerants and Lubricants

Approved Refrigerants

The Paragon low/medium temperature duty screw compressor is specifically designed for use in single or parallel compressor R-404A, R-407A, R-407C, R-407F, and R-507A systems.

Approved Lubricants

The Paragon screw compressor is approved for use with the following lubricants:

Approved Lubricant - Solest 170

Viscosity Grade - ISO 170

Assembly Grease

On occasion, it may be necessary to use an assembly grease to retain an O-ring within its groove. The following assembly grease is approved for use with the Paragon screw compressor:

Approved Grease - Castrol Synplex GP2

Or

Approved Grease - Parker Super-O-Lube

Carrier Part Number - 19XL680001

Terminal Pin Dielectric Grease

Carlyle recommends that compressor motor terminal pins are coated with dielectric grease (P/N 06TT660050)

to reduce the effects of condensation that may form on the terminal pins.

3.2 Environmental Considerations

Operating Ambient Temperature

The screw compressor is designed for the following ambient temperature ranges:

Non-operating: -40 F to 176 F (-40 C to 80 C)

Operating: -31 F to 131 F (-35 C to 55 C)

Salt-Spray Requirements

The compressor has been tested through 500 hours of salt-spray in compliance with ASTM specification B-117.

3.3 Operating Limits and Controls

Low and Medium Temperature Operating Envelopes

The following low and medium temperature operating envelopes show where the compressor can be operated in both water-cooled and air-cooled direct expansion applications. See Fig. 10 and Fig. 11.

The Motor Cooling and Discharge Gas De-Superheating lines are added to the envelopes to provide guidance for OEM customers.

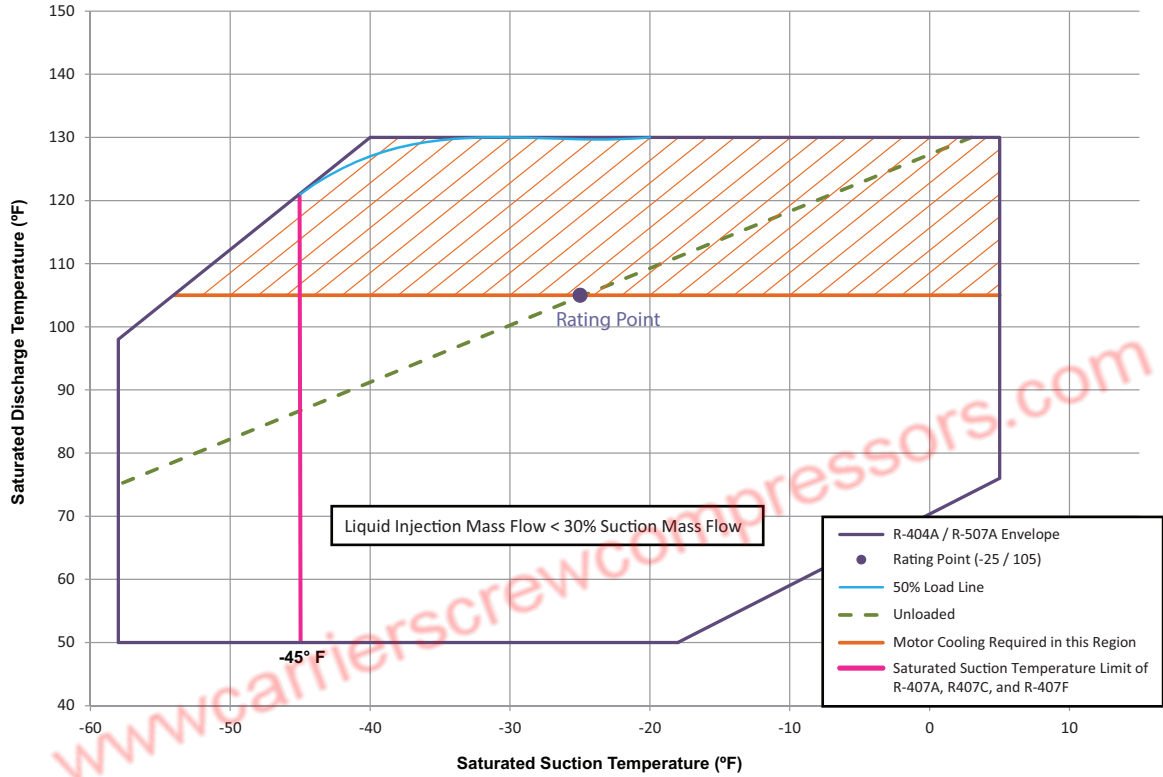

Fig. 10 — Paragon Low Temperature Operating Envelope

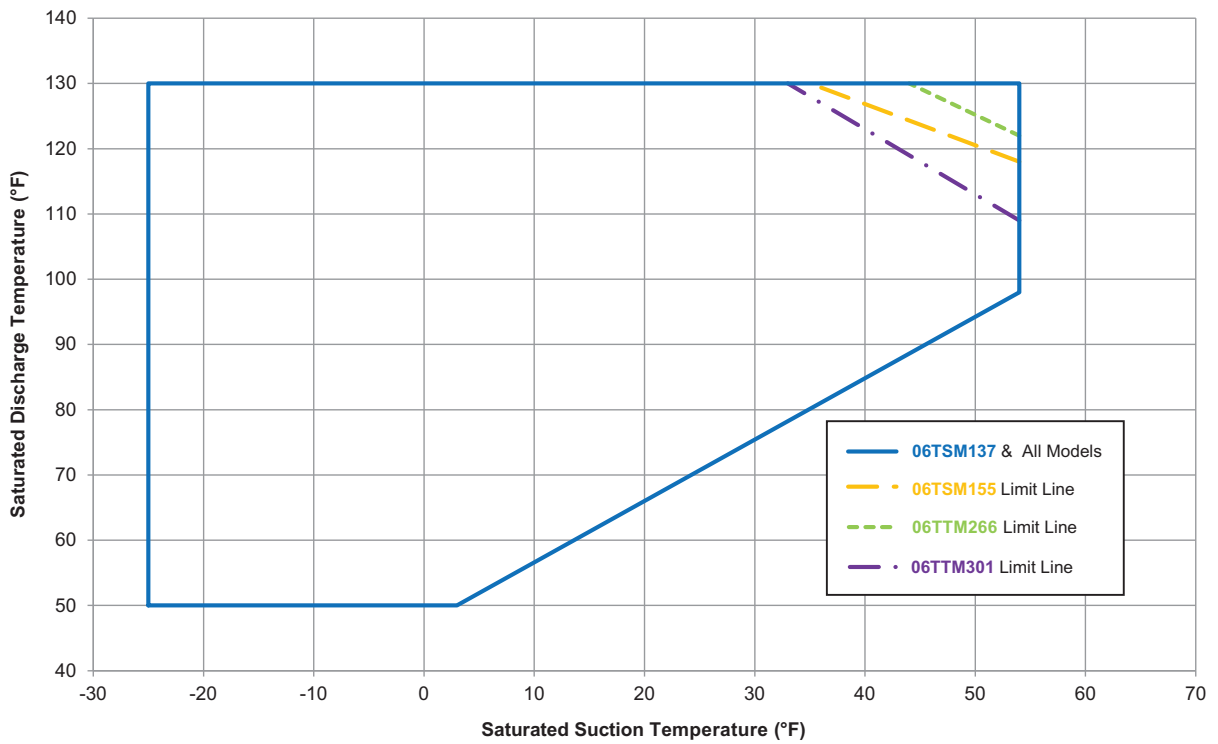

Fig. 11 — Paragon Medium Temperature Operating Envelope

Start-Up and Suction Pressure Transients

Operating a screw compressor without refrigerant flow through the compressor can be harmful. When this occurs, the evaporator typically will go into a vacuum, leading to very high pressure ratios and little mass flow to carry the heat away from the screw rotors. This situation most often occurs during start-up when the refrigerant may be in another part of the system. This is tolerable for short periods of time. The Paragon screw compressor should not be allowed to operate with a suction pressure less than 0 psig (vacuum) for more than 1 minute after a “cold” start. (Contact Carlyle Application Engineering for more information on cold starts.)

If a compressor is allowed to operate for longer periods of time without refrigerant flow, catastrophic damage may occur to the screw rotors, rotor housing, and discharge housing, requiring compressor replacement.

Oil Supply at Compressor

To reduce the possibility of liquid refrigerant becoming entrained in the oil during an OFF cycle, it is recommended that the temperature of the oil entering the compressor is kept above the outdoor ambient temperature, as shown in Fig. 12. See Section 4.0 for additional information.

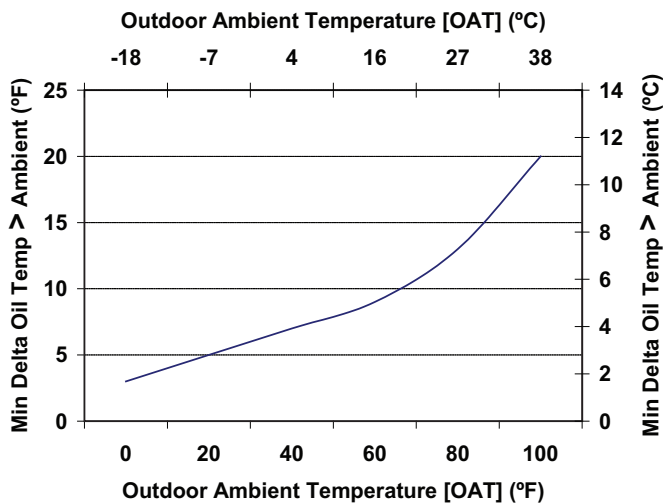

Fig. 12 — Oil Temperature

Allowable Temperature Ranges

CONTROL POINT	MINIMUM	MAXIMUM
Discharge Gas	20 F (11 C) superheat	210 F (99 C)
Economizer Gas	Saturated Liquid	9 F (5 C) superheat
Suction Gas	Saturated Vapor	Can float if motor and discharge maximum temps are met
Oil Supply at Compressor	Refer to Fig. 12	140 F (60 C)
Motor Windings	No limit	275 F (135 C)

Unloader System Control Points

The table below shows the proper control states for the slide valve solenoids. See Fig. 13 for solenoid locations.

Table 7: Proper Slide Valve Control States

	INCREASE CAPACITY	DECREASE CAPACITY	PARTIAL*
SOLENOID #1	Energized	De-Energized	De-Energized
SOLENOID #2	Energized	De-Energized	Energized

* Maintain capacity: Solenoid activation after proper slide valve position has been attained.

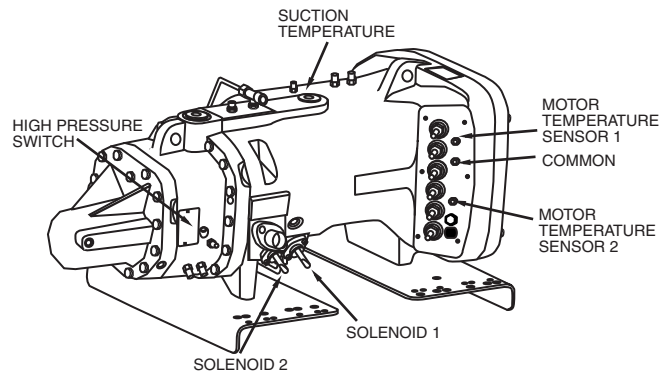

Fig. 13 — Solenoid Locations

The compressor will start with minimum power draw in the fully unloaded state. There is no minimum or maximum time limit immediately after start-up for which the compressor must operate in the unloaded state.

However, it is recommended that the compressor operates unloaded for a minimum load for 30 seconds just prior to shut down. This will ensure the compressor is fully unloaded on the subsequent start, and means that the compressor is drawing the minimum current when the contactors open to shut down the compressor.

Certain fully unloaded operating conditions may result in discharge gas temperatures that exceed the recommended operating parameters. Carlyle requires that some form of liquid injection be applied to control/reduce discharge gas temperatures to be within recommended guidelines. Common methods used to accomplish this may include increased flow through the economizer circuit or direct liquid injection into the economizer port/tubing. Please refer to Refrigeration System Design Considerations at the end of this section. Also see Fig. 14 and Section 9.9.3 for additional information.

Compressor Rotation Control

Correct compressor rotation is one of the most critical application considerations. Powered reverse rotation, even for a very short duration, can seriously affect the reliability of the compressor.

The reverse rotation protection scheme must be capable of determining the direction of rotation and stopping the compressor within 1 second.

Reverse rotation is most likely to occur at initial start-up or whenever the wiring to the compressor terminals is disturbed. To minimize the possibility for reverse rotation operation, Carlyle recommends the following procedures:

1. During initial run test of the unit, a suitable low-pressure switch should be temporarily installed on the high-pressure port of the compressor and be wired to open the compressor control circuit. The purpose of this switch is to protect the compressor against any wiring errors at the compressor terminal pins. The electrical contacts of the switch must be wired in the control circuit of the compressor start components to shut off the compressor in the event it is operating in reverse rotation. This switch would remain in place for the duration of the run test. At the end of the run test the switch would be removed for use on the next unit or compressor to be tested.
2. For service replacement compressors, a similar protection system is recommended. The unit service literature will make reference to this switch and provide instructions on how to temporarily install the low pressure switch into the safety circuit for the compressor. Each service compressor will be supplied with Installation Instructions documenting the procedure for installing and using the switch.

The switch will remain in place until the compressor has been started and direction of rotation has been verified, at this point the switch will be removed.

The low pressure switch must be suitable for the pressures consistent with R-404A systems, and the switch must be manually resettable and open when the pressure falls below 50 mm (2 inches) of vacuum. The switch is a "Manual Reset" type that can be reset only after the pressure has risen above 1.7 bar (25 psia). It is critical that

the switch be a "Manual Reset" type to preclude the compressor from short cycling in the reverse direction.

If a switch is not available, a manifold gage can be used so long as it is connected to the discharge housing of the compressor BEFORE THE DISCHARGE CHECK VALVE. If the compressor can be "bumped" or "jogged" very quickly (< 1 second) while someone is watching the gage, compressor rotation can be determined without damage to the compressor. If the pressure drops, the compressor is rotating backwards and will have to be rewired. If the pressure rises, the compressor is spinning in the correct direction.

Refrigeration System Design Considerations

In order to eliminate the possibility of refrigerant migrating into the oil separator and compressor, Carlyle requires the application of a positive-seal, discharge check valve (or a similar functioning device) to be installed in the discharge line after the oil separator. See Fig. 14.

Certain operating conditions may result in motor temperatures and/or discharge gas temperatures that exceed the recommended operating parameters.

Carlyle's Solutions software can be used to estimate the discharge temperature for a given application. The oil cooler does offer some help in keeping the discharge and motor temperatures within their required limits. However, oil cooling alone is not sufficient to adequately control motor and discharge gas temperatures within their respective acceptable ranges.

Carlyle requires that some form of liquid injection be applied to control/reduce motor and discharge gas temperatures to be within recommended guidelines.

Motor cooling valves are available through Carlyle, and they should be applied to inject liquid into the compressor suction line (see Fig. 14). For Paragon screw compressor applications, this injection is accomplished using a motor-cooling valve that injects liquid into the suction line entering the compressor.

Carlyle also offers de-superheating valves. These valves inject liquid at the economizer line or economizer port to assist in controlling discharge gas temperatures (see Fig. 14). For Paragon screw compressor applications, discharge gas temperature control is accomplished using a de-superheating valve that injects liquid into the economizer port or the economizer line (after the liquid refrigerant subcooler).

Because refrigerant injection for discharge gas cooling eventually flows into the screw rotor chamber after the suction gas is trapped, compressor capacity is not significantly affected.

Carlyle recommends a Sporlan Y-1037 de-superheating valve (or an equivalent) for operating conditions that require additional discharge gas de-superheating. The selected valve should be selected to start opening at a discharge temperature of 190 F (88 C) and be fully open at 200 F (93 C). The bulb should be located on the discharge line within 6 in. of the compressor discharge service valve. A properly sized solenoid valve should be located upstream to ensure positive shutoff when the compressor is off.

Please see Section 9.9.3 for de-superheating valve sizes and part number information.

Carlyle recommends the application of our qualified Safety Control Module package (Carlyle P/N 6BSB000929 [R-134a] and 6BSB000930 [R-404A, R-407A, R-407C, R-407F, and R-507A]), which provides the following safety control functionality:

- Discharge Temperature Monitoring
- Oil Level Monitoring (Optional)
- Reverse Rotation Monitoring
- Oil Flow-Rate/Supply Monitoring
- Capacity Control/Slide Valve Control

Technical documentation for this Safety Control Module package is provided on the Carlyle website at www.carlylecompressor.com

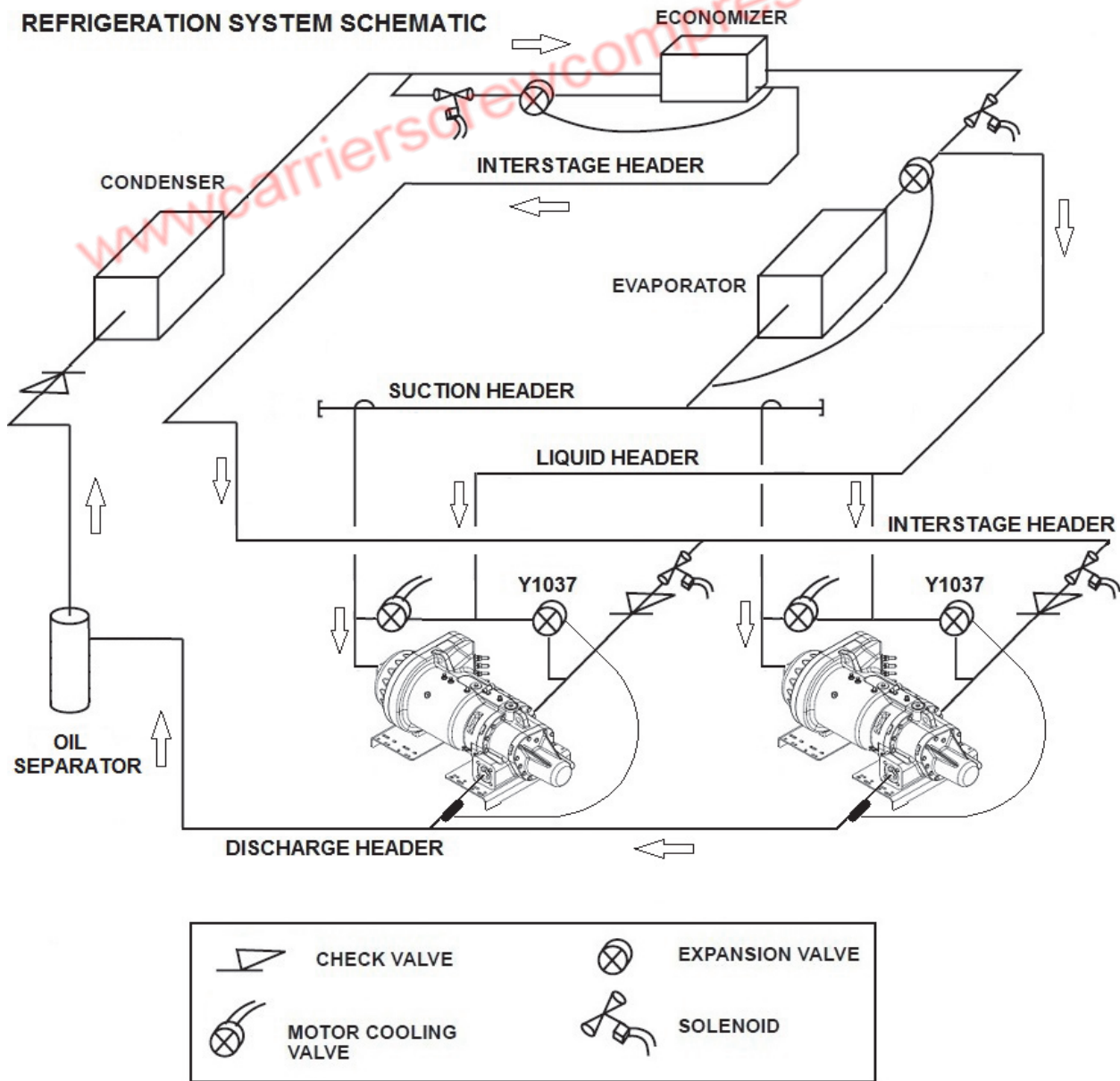

Fig. 14 — Refrigeration System Schematic

3.4 Control Points Summary

<p>Reverse Rotation / Operation with Suction Pressure in Vacuum</p> <ul style="list-style-type: none"> Control must detect and prevent reverse rotation of the compressor within 1 second of compressor start-up. Compressor must not operate in a vacuum, as measured at the suction pressure port, for greater than 1 minute.
<p>Oil Pressure Confirmation / Safety</p> <ul style="list-style-type: none"> Three pressures must be observed to ensure that the oil pressure is suitable for compressor operation: suction, discharge, and oil. Oil pressure safety control must be manually reset. Oil pressure must be maintained as follows: <ol style="list-style-type: none"> $P_{OIL} > [0.7 \times (P_{DISCHARGE} - P_{SUCTION}) + P_{SUCTION}]$ $P_{OIL} > [P_{SUCTION} + 0.5 \text{ bar}]$ 15 seconds after start (Air-cooled models; <i>A</i> in 5th digit of model numbers) $[P_{SUCTION} + 1.0 \text{ bar}]$ 45 seconds after start (Refrigeration models; <i>R</i> in 5th digit of model numbers) $[P_{SUCTION} + 1.0 \text{ bar}]$ 75 seconds after start (Water-cooled models: <i>W</i> in 5th digit of model numbers)
<p>Oil Supply Confirmation / Oil Level Switch</p> <ul style="list-style-type: none"> Oil supply to the compressor must be maintained during operation at all times. Compressor operation must be stopped if the required oil level switch is open for 5 continuous seconds. Oil supply solenoid valve must be closed during OFF cycles.
<p>Oil Filter Differential Pressure</p> <ul style="list-style-type: none"> Compressor operation must be stopped if the pressure differential measured between the entering and leaving oil filter locations exceeds 2 bar. The oil filter supply tubing design should apply valves to allow for the isolation and replacement of the filter without removing the system refrigerant charge.
<p>Motor Temperature Limitation</p> <ul style="list-style-type: none"> Motor temperatures must be continuously monitored during compressor operation. Motor temperatures must not exceed 275 F (135 C). Liquid injection into the suction line may be required.
<p>Compressor Short Cycling</p> <ul style="list-style-type: none"> Control must provide for a 10-minute minimum time delay before restarting the Paragon compressor. The maximum number of compressor START cycles per hour is 6.
<p>Maximum Discharge Gas Temperature</p> <ul style="list-style-type: none"> Discharge gas temperatures must not exceed 210 F (99 C). Liquid injection into economizer inlet port may be required. Control must prevent compressor operation when discharge gas temperatures exceed this maximum.
<p>Maximum Oil Temperature</p> <ul style="list-style-type: none"> Oil temperatures must not exceed 115 F (46 C). Oil cooling will be required for most applications. Control must prevent compressor operation when oil temperatures exceed this maximum.
<p>Run-Proof</p> <ul style="list-style-type: none"> Current must be monitored to detect welded contacts on a contactor or single-phase condition. Oil flow must be resumed if a contactor is determined to be welded shut. Compressor must be shut down if a single-phase condition is detected.
<p>Liquid Line Solenoid / Economizer</p> <ul style="list-style-type: none"> A liquid line solenoid valve is required to shut off liquid flow to the compressor during OFF cycles. Controlling this valve allows for additional capacity reduction during low load conditions.
<p>Unloading Control</p> <ul style="list-style-type: none"> Control must be provided to the two unloader coils. These coils position the slide valve mechanism within the compressor and allow for infinite unloading valve positioning.
<p>Unloaded Shutdown</p> <ul style="list-style-type: none"> It is recommended that the compressor operate for 30 seconds fully unloaded prior to shut down. This ensures fully unloaded re-start will occur.

NOTE: Carlyle offers Compressor Protection Module package P/N 6BSB000603, which protects against reverse rotation, low oil flow, and maximum discharge gas temperature. See Marketing Bulletin 14M-01 at www.carlylecompressor.com.

4.0 Low/Medium Temperature System Oil Management (R-404A, R-407A, R-407C, R-407F, R-507A)

Oil supply system components are shown in Fig. 15.

4.1 Oil Pressure Requirements

System pressure is used to generate the oil pressure required to lubricate bearings and provide the oil that acts as a seal between the screw rotors and the bores. Oil pressure is monitored continuously during compressor operation. The oil pressure must meet the following criteria, based on $P_{DISCHARGE}$, $P_{SUCTION}$, and P_{OIL} , as shown in Fig. 17, Oil System Schematic:

1. $P_{OIL} > [0.7 \times (P_{DISCHARGE} - P_{SUCTION}) + P_{SUCTION}]$
2. $P_{OIL} > [P_{SUCTION} + 0.5 \text{ bar}]$ 15 seconds after start (Air-cooled C models; A in 5th digit of model numbers)
[$P_{SUCTION} + 1.0 \text{ bar}$] 45 seconds after start (Refrigeration models; R in 5th digit of model numbers)
[$P_{SUCTION} + 1.0 \text{ bar}$] 75 seconds after start (Water-cooled models: W in 5th digit of model numbers)

The unit control system must monitor the oil pressure differential, as well as the operating condition, so the compressor can be shut down if the minimum requirements are not met for any duration exceeding 15 seconds.

This time delay has two functions: first, to avoid nuisance tripping during normal and transient operation, and second, to allow the system sufficient time to develop pressure differential during start-up.

The compressor must be shut down and prevented from restarting when the low oil pressure safety is tripped.

The safety should be a manual reset type that locks out compressor operation until the system is serviced.

Carlyle offers a Compressor Protection Module package to provide protection against loss of oil flow, reverse-rotation, and elevated discharge gas temperature. Application of this package provides equal alternate protection to the method described above. The Carlyle R-404A Compressor Protection Module package part number is 6BSB000603.

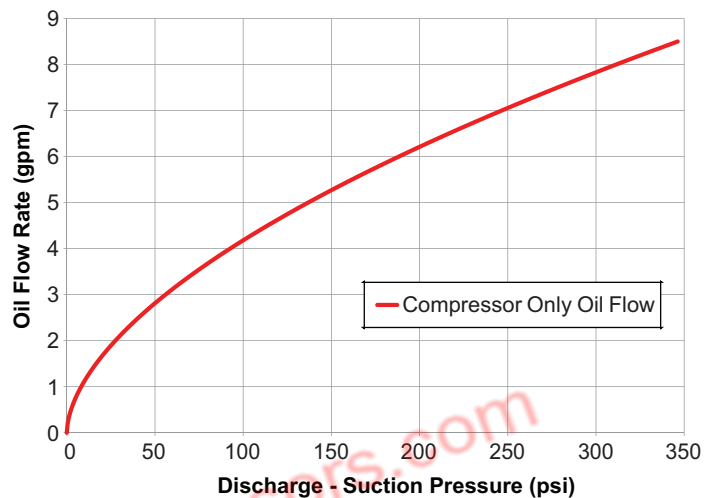

Fig. 15 — Oil Supply at Compressor

4.2 Oil Separator Recommendations

The low/medium temperature Paragon compressor will require an oil separator. The combined oil capacity of the oil separator sump, the oil reservoir, and the oil cooler will vary greatly depending on system design and the number of compressors applied. Carlyle recommends that the oil reservoir of the system is large enough to hold 4 gallons of oil for each compressor applied.

Contact Carlyle Application Engineering for additional oil separator information.

4.3 Oil Heater Recommendations

For the typical oil separators used with the Paragon compressor, a 500-watt flexible-band heater is recommended. The heater should be wired to operate when the compressor is OFF. This minimizes the migration of refrigerant to the oil stored in the oil separator reservoir. Carlyle recommends monitoring the temperature of the oil in the oil separator reservoir. If oil temperatures climb above 190 F (88 C), the heater element should be de-energized to prevent oil overheating.

Figure 12 shows the minimum oil temperatures that must be maintained when the compressor is not operating based on the outdoor ambient temperature (OAT).

4.4 Oil Level Safety Switch

An oil level safety switch must be installed in the sump of the oil separator or the oil reservoir, depending on the system design. Carlyle recommends a float style switch, which opens if the oil level falls below a safe point.

Enough oil should remain in the sump when the switch is opened for the compressor to operate for at least one minute before completely running out of oil.

To reduce the possibility of false oil level alarms, Carlyle recommends that the oil level safety switch should be open continuously for 5 seconds prior to initiating a compressor shutdown.

4.5 Oil Filter

Provisions should be made to isolate the oil filter using some combination of shutoff valves and/or check valves. See Fig. 17.

This will allow for the filter element to be replaced without removing or isolating the charge in the unit. The oil filter must be installed after the oil cooler and as close to the compressor as feasible.

Because of the long bearing life requirements, filtration for this compressor is very stringent. The beta ratio for this filter is greater than or equal to 200 for a 5 micron particle size evaluated using ISO 16889.

Filter areas must also be sufficient to avoid premature clogging of the filter during normal operation. The Carlyle supplied filters have a filtration area of $> 5000 \text{ cm}^2$. Carlyle recommends monitoring the pressure differential across the oil filter. An alarm should be activated if the differential pressure exceeds 2 bar (29 psig), and the oil filter should be replaced.

4.6 Oil Cooling Systems

Carlyle's 06TSR/TTR refrigeration-duty and 06TSM/TTM medium-temperature-duty compressor models require oil cooling for all operating points in the application envelope. The oil temperature entering the compressor is to be maintained at 115 F (46.1 C) at all times over the range of operation.

Be aware that air-cooled oil coolers may not be suitable for applications that have very high design saturated discharge temperatures. The maximum oil temperature entering the compressor is 115 F (46.1 C). If the design outdoor ambient air temperature for the application is greater than 115 F (46.1 C), an alternate oil cooling method should be selected.

Carlyle offers a complete line of air-cooled oil coolers to assist systems designers. Please see Section 9.9.1. A mixing valve is recommended for all oil coolers circuited through a remote air-cooled condenser.

4.7 Oil Cooler Selection

An oil cooler is required for all Paragon low/medium temperature screw compressor applications. As noted in Section 4.6, the maximum oil temperature entering the compressor may not exceed 115 F (46.1 C).

Carlyle's Solutions software calculates the oil cooler load based on the operating parameters and compressor models selected. The oil cooler must maintain the oil temperature entering the compressor at 115 F (46.1 C) maximum over the range of operation.

Several methods exist to control oil temperature, including:

- Oil cooler fan cycling based on oil outlet temperature (measured at the outlet of the oil cooler, controlled to $10 \text{ F } \Delta T$)
- Oil cooler bypass via a solenoid valve, controlled by the temperature of the oil entering the oil cooler.
- Use of a mixing valve to maintain a constant oil temperature entering the compressor.
- Some combination of the three methods listed above.

The oil may be cooled by means of air-cooled, refrigerant-cooled, or water-cooled oil coolers. Following are selection criteria for the various models, along with dimensional information.

If using a refrigerant-cooled oil cooler, the oil cooling load will need to be subtracted from either the compressor's evaporator capacity or the subcooling capacity, depending on where the oil cooler's suction gas flow enters the compressor. The superheated gas from refrigerant-cooled oil coolers may be connected to the economizer port or the suction line of the compressor.

Using a compressor suction port will lead to a reduction in system capacity since some of the compressor suction mass flow will now come from the oil cooler.

Using the compressor interstage port for oil cooling will not reduce the compressor suction pumping capacity, but will indirectly reduce system capacity by decreasing the compressor's ability to perform liquid subcooling.

The additional mass flow from the oil cooler to the interstage will increase the interstage pressure. This method will marginally raise the economizer pressure, which may increase the liquid temperature of the liquid refrigerant subcooler.

Both methods will require holdback valves to prevent the oil temperature from dropping below 80 F (27 C).

The heat rejected from the oil cooler may be used for heat reclaim processes, such as water heating. Since the oil cooler rejects some discharge heat, the heat rejection from the oil cooler must be considered when sizing the system condenser (unless a refrigerant-cooled oil cooler is used). This may allow the application of a smaller condenser.

Condenser circuiting may also be used for oil cooling; however, pressure drops must be taken into account for minimum oil pressure differential to the compressors.

4.8 Oil Cooler Sizing

An oil cooler is required for all LT and MT applications using R-404A, R-407A, R-407C, R-407F, and R-507A, and may be required for R-134a, depending on the

operating condition. Size the oil cooler by using *Oil Cooling Load* featured in the Carwin software (see Fig. 16) and Table 8 below.

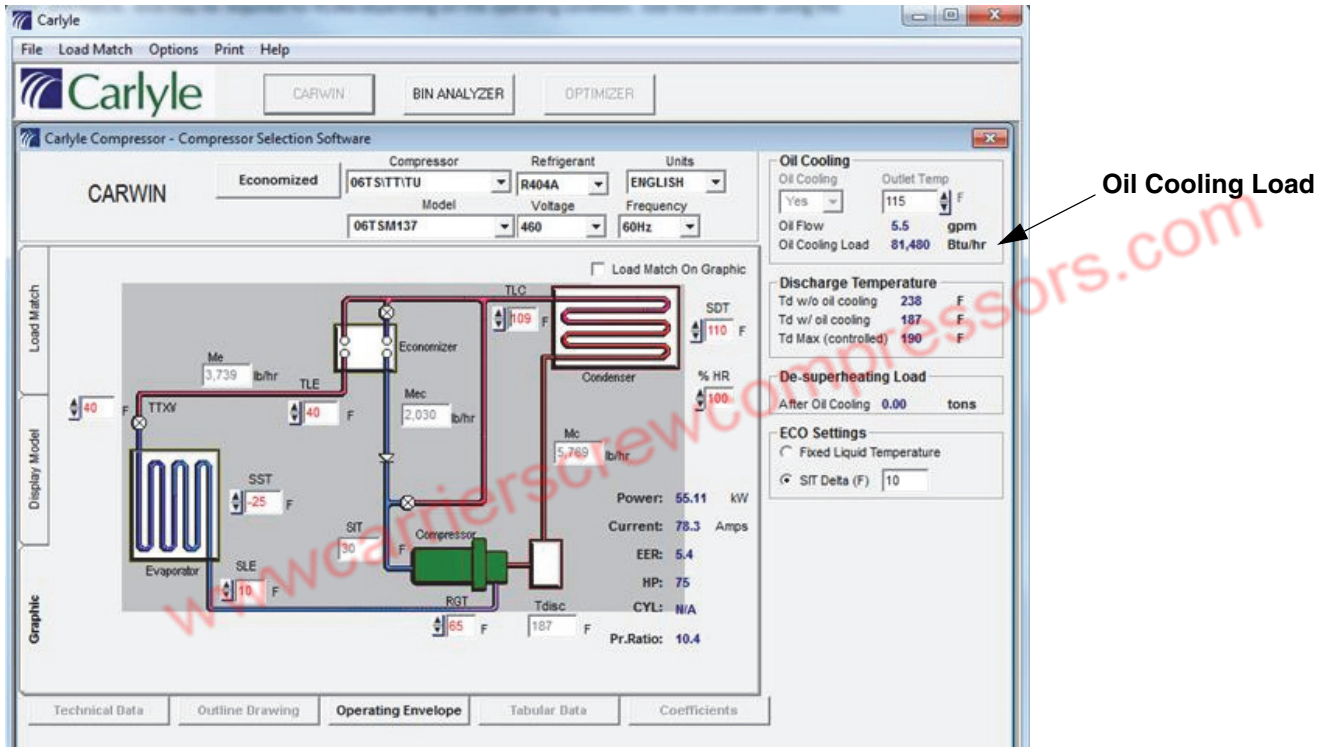

Fig. 16 — Carwin Software Interface Display

Table 8: Available Oil Cooler Models

FAN SPEED	PART NUMBERS	OIL COOLING CAPACITY AT AMBIENT AIR TEMPERATURE			
		95 F (35 C)	100 F (38 C)	105 F (41 C)	110 F (43 C)
50 Hz	KH51ZZ181 (2 Compressors Max)*	32,200 Btu/Hr (9,405 W/Hr)	28,800 Btu/Hr (9,435 W/Hr)	27,300 Btu/Hr (8,438 W/Hr)	25,900 Btu/Hr (7,999 W/Hr)
	KH51ZZ182 (3 Compressors Max)*	63,700 Btu/Hr (18,664 W/H)	60,600 Btu/Hr (17,756 W/Hr)	57,600 Btu/Hr (16,877 W/Hr)	54,600 Btu/Hr (15,998 W/Hr)
	KH51ZZ183 (4 Compressors Max)*	94,900 Btu/Hr (27,805 W/Hr)	90,400 Btu/Hr (26,487 W/Hr)	85,900 Btu/Hr (25,168 W/Hr)	81,400 Btu/Hr (23,850 W/Hr)
	KH51ZZ184 (5 Compressors Max)*	123,400 Btu/Hr (26,156 W/Hr)	117,500 Btu/Hr (34,427 W/Hr)	111,600 Btu/Hr (32,699 W/Hr)	105,800 Btu/Hr (30,999 W/Hr)
60 Hz	KH51ZZ181 (2 Compressors Max)*	32,100 Btu/Hr (9,405 W/Hr)	30,600 Btu/Hr (8,966 W/Hr)	29,000 Btu/Hr (8,497 W/Hr)	27,600 Btu/Hr (8,087 W/Hr)
	KH51ZZ182 (3 Compressors Max)*	69,100 Btu/Hr (20,246 W/H)	65,700 Btu/Hr (19,250 W/Hr)	62,400 Btu/Hr (18,283 W/Hr)	59,100 Btu/Hr (17,316 W/Hr)
	KH51ZZ183 (4 Compressors Max)*	102,600 Btu/Hr (30,061 W/Hr)	97,700 Btu/Hr (28,626 W/Hr)	92,800 Btu/Hr (27,190 W/Hr)	87,900 Btu/Hr (25,755 W/Hr)
	KH51ZZ184 (5 Compressors Max)*	134,100 Btu/Hr (39,291 W/Hr)	127,700 Btu/Hr (37,416 W/Hr)	121,300 Btu/Hr (35,541 W/Hr)	114,900 Btu/Hr (33,665 W/Hr)

* Maximum number of compressors based on oil cooler pressure drop of less than 6 psid (0.41 bar).

OIL SYSTEM SCHEMATIC

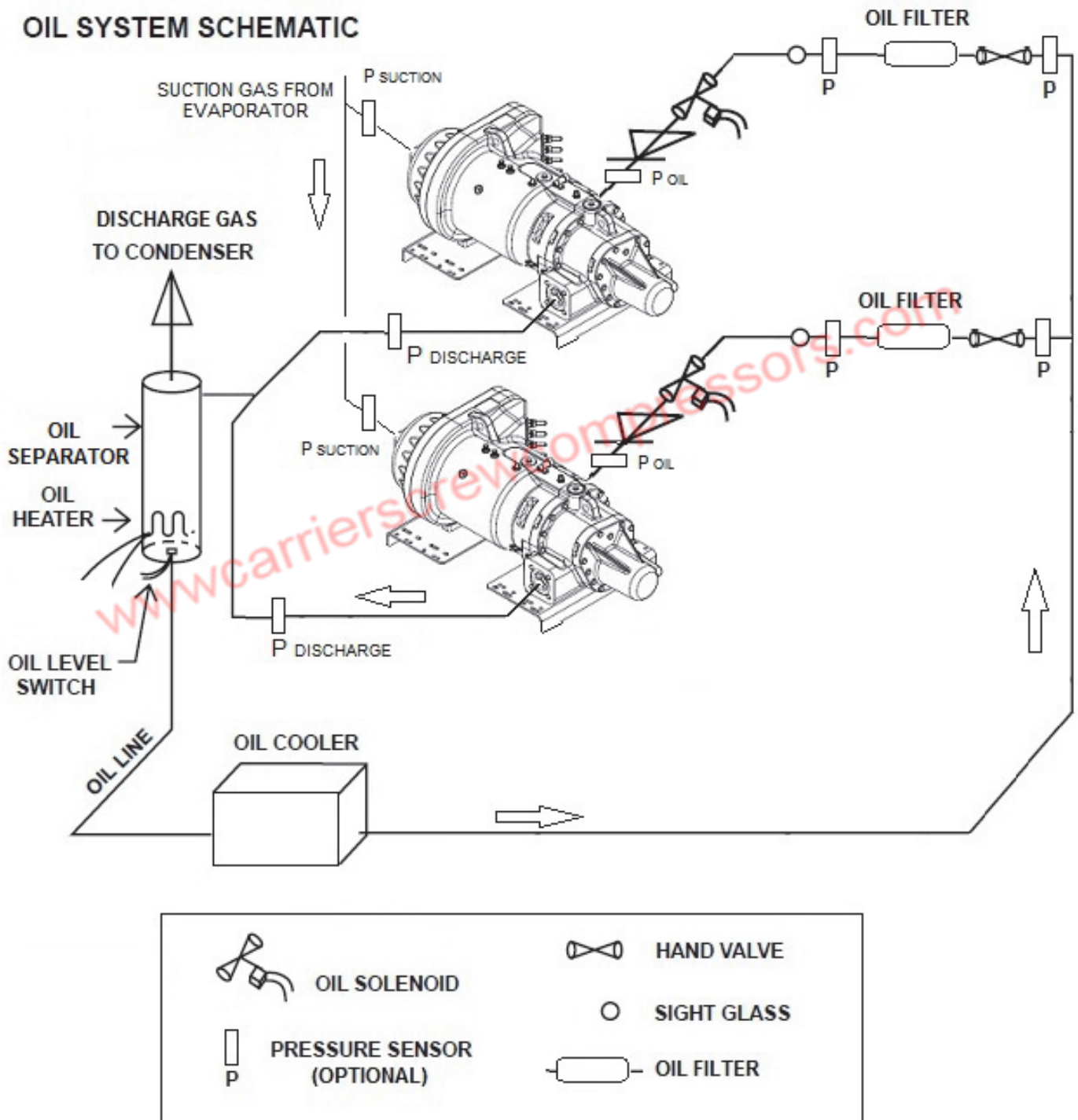

Fig. 17 — Oil System Schematic

5.0 Unloader Operation

All Paragon compressors come equipped with an infinitely adjustable slide valve unloading system. The actual capacity reduction will depend on the system operating conditions and the rebalance characteristics.

Two solenoids control the slide valve by allowing communication between the unloader piston chamber and either high-pressure oil or low-pressure suction.

- To fully load the compressor, both solenoid #1 and #2 are energized (see Fig. 18). This allows high-pressure oil to enter the unloader piston chamber, moving the slide valve and providing more engagement under the screw rotors. Both solenoids should remain energized to maintain the full load position.

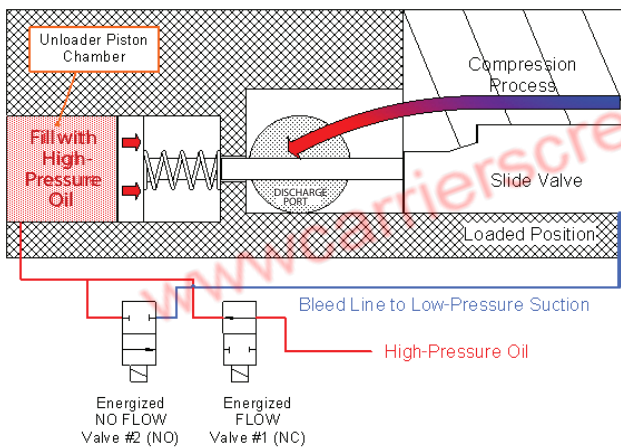

Fig. 18 — Fully Loaded Operation

- To unload the compressor, both solenoids are de-energized (Fig. 19). This exposes the unloader piston chamber to suction pressure, pulling the slide valve out from under the screw rotors and reducing the amount of compression being performed.

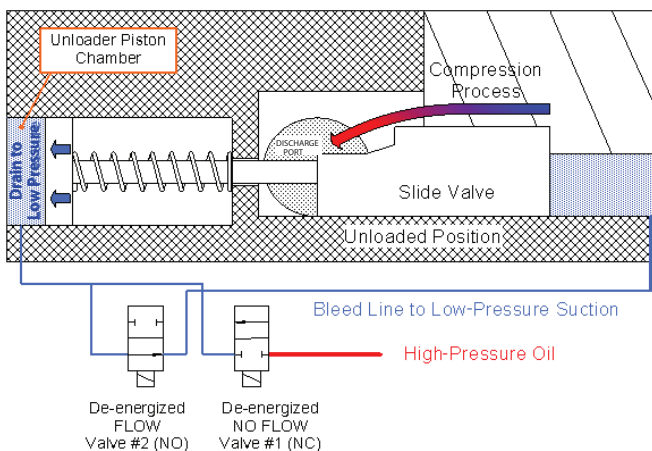

Fig. 19 — Configuration for Unloading

- Part load is achieved by stopping the load or unload process previously described at an intermediate slide valve position. Stopping the valve at an intermediate position is accomplished by de-energizing valve #1 and energizing valve #2 (Fig. 20). When this happens, both valves are closed and the piston is not allowed to move. Cycling of the solenoids may be required to compensate for leakages around the piston seal, etc.

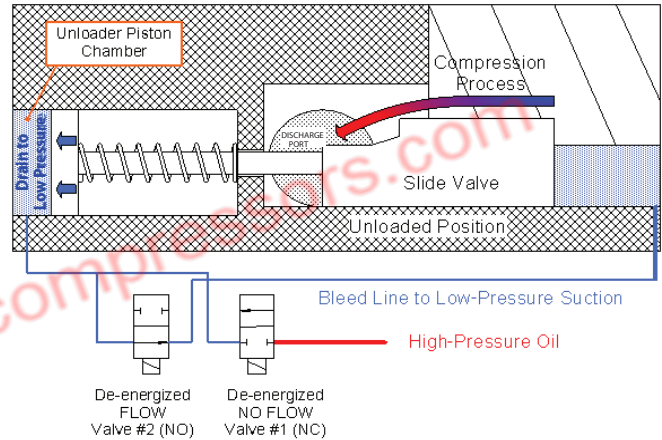

Fig. 20 — Configuration for Maintaining Part Load

The TU and TV water-cooled models have a hot gas bypass port on the slide valve. This feature allows discharge gas to leak back to suction through the slide valve when the slide valve is in the fully unloaded position. The hole is closed at all other load states. The purpose of this feature is to allow the compressor to unload to 15% of the full load capacity.

The compressor will start with minimum power draw in the fully unloaded state. There is no minimum or maximum time limit immediately after start-up for which the compressor must operate in the unloaded state. However, it is recommended that the compressor operates unloaded for a minimum load for 30 seconds just prior to shutdown. This will ensure the compressor is fully unloaded on the subsequent start, and means that the compressor is drawing the minimum current when the contactors open to shut down the compressor.

5.1 Unloader System Control Points

The table below shows the proper control states for the slide valve solenoids. See Fig. 21 for solenoid locations.

Table 9: Proper Control States for Slide Valve Solenoids

	INCREASE CAPACITY	DECREASE CAPACITY	PARTIAL*
SOLENOID #1	Energized	De-Energized	De-Energized
SOLENOID #2	Energized	De-Energized	Energized

* Maintain capacity: Solenoid activation after proper slide valve position has been attained.

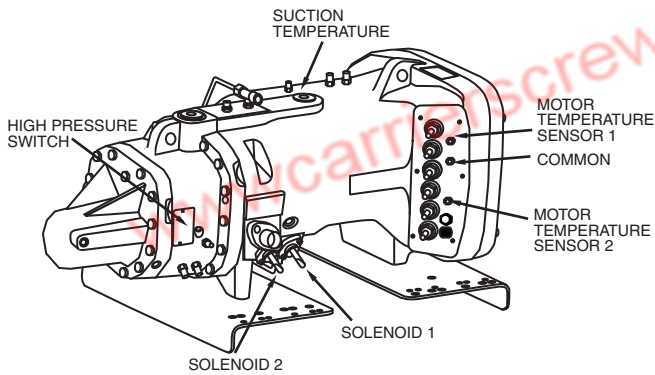

Fig. 21 — Solenoid Locations

5.2 Approximate Part Load Factors

The table below shows the typical relation of part load capacity and power at their respective rating conditions. Contact Carlyle Application Engineering for further information.

% FULL LOAD CAPACITY	AIR-COOLED (R-134a)	WATER-COOLED (R-134a)
	% FULL LOAD POWER	% FULL LOAD POWER
100	100	100
75	78	78
50	58	58
34	50	50
15	—	50

Certain fully unloaded operating conditions may result in discharge gas temperatures that exceed the recommended operating parameters. Carlyle requires that some form of liquid injection be applied to control/reduce discharge gas temperatures to stay within recommended guidelines. Common methods to accomplish this may include increased flow through the economizer circuit or direct liquid injection into the economizer port/tubing.

5.3 Slide Valve Capacity Controller and Protection

5.3.1 General Description

The Paragon Control Module (PCM) will function to control compressor capacity by operating the compressor's slide valve to maintain the system's control set point (suction pressure or temperature). This process control point is an input to the PCM. In addition, the PCM will have functionality to protect the compressor and provide LED fault status indication for:

- Oil Level Protection
- Oil Flow Protection
- Motor Cooling Protection
- Discharge Temperature Protection
- Transducer Sensor Failure
- Temperature Thermistor Failure

The following Paragon capacity and protection kits 6BSB000929 and 6BSB000930 are available through Carlyle. Detailed information regarding the Paragon Slide Valve controller may be found at www.carlylecompressor.com, Application Guide 575-012.

5.3.2 PCM Configuration

The PCM can be configured to function in the following 3 modes of operation:

1. Slide Valve Control and Compressor Protection (Default Setting).
2. Slide Valve Control only.
3. Compressor Protection only.

Configuring the PCM for options 2 or 3 can be accomplished through:

- Using the BACview* hand-held display unit.
- Downloading BACview software to a laptop.
- Setting up a communication port between the PCM and System Controller.

To allow easier transmission of data across a network between the PCM and the System Controller, the PCM is preconfigured with the following protocol networks:

- BACnet†
- Modbus**
- N2 Open
- LonWorks†† (requires optional card)
- RS485 Communication Port

CARLYLE P/N	DESCRIPTION	APPLICATION
6BSB000929	High Temperature Paragon Controller Kit	R-134a
6BSB000930	Low/Medium Temperature Paragon Controller Kit	R404A, R-407A, R-407C, R-407F, R-507A
6BSB000931	Transducer Kit	Required if control variable is pressure
USB-L	PCM Interface Cable	Cable interface between controller and laptop

*BACview is a registered trademark of Automated Logic Corporation.

†BACnet is a registered trademark of ASHRAE (American Society of Heating, Refrigeration and Air-Conditioning Engineers).

**Modbus is a registered trademark of Schneider Electric.

†† LonWorks is a registered trademark of Echelon Corporation.

5.3.3 PCM Inputs/Outputs

Figure 22 shows the inputs and outputs of the Paragon Control Module.

Network communication port for BACnet, Modbus, N2, and LonWorks.

LonWorks requires the user to install an additional network card (not provided by Carlyle).

Field Service Connection for laptops to connect to and download PCM software; also connects the BACview display module for field service. Requires Carlyle interface cable P/N USB-L.

Input #1: 5-vdc Pressure Transducer or NTC Thermistor for process control of set-point.

Input #2: Motor Temperature Thermistor. Wire this input to Terminals S1 and C in the compressor electrical box.

Input #3: 5K NTC Discharge Temperature Thermistor. Field installed in compressor thermo-well.

Input #4: Dry Contact for Compressor Oil Level Switch and Oil Flow Switch. Wire the devices in series.

Input #5: Dry Contact for Compressor Run Recognition Signal from the System Controller to the PCM. Lets the PCM know the status of the compressor (ON or OFF).

Input #6: Dry Contact for manual reset switch. Following any compressor alarm, the manual reset button will need to be pushed to reset the PCM after the alarm is cleared. Wire the switch to input IN-6 and Gnd.

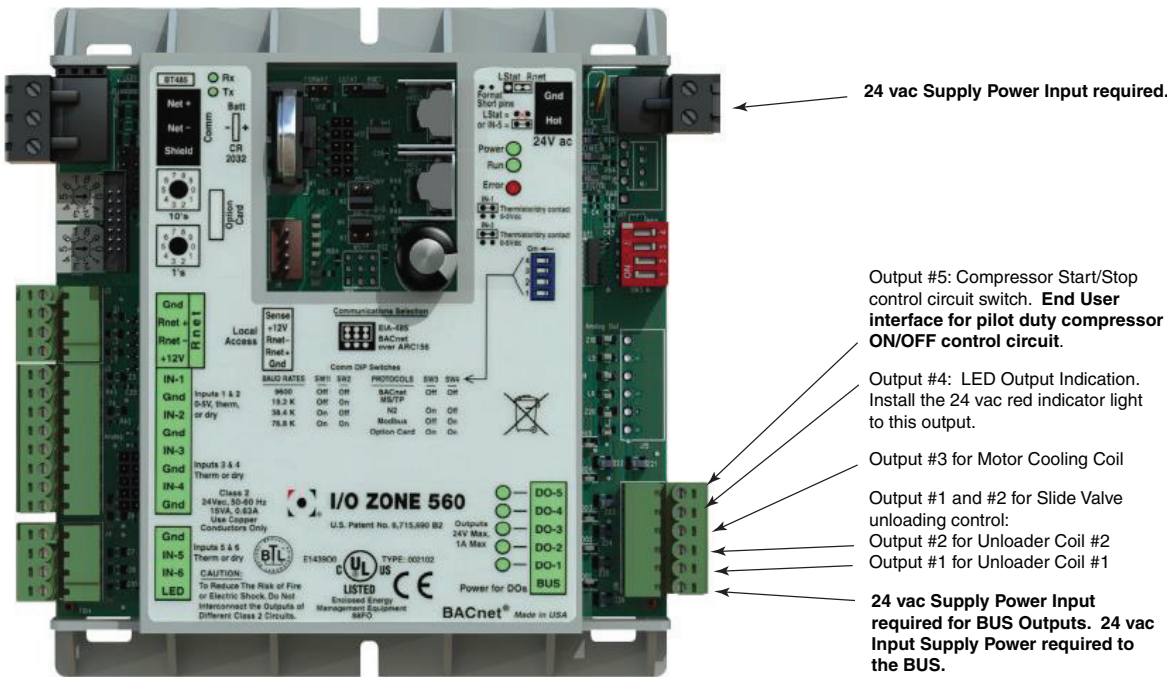
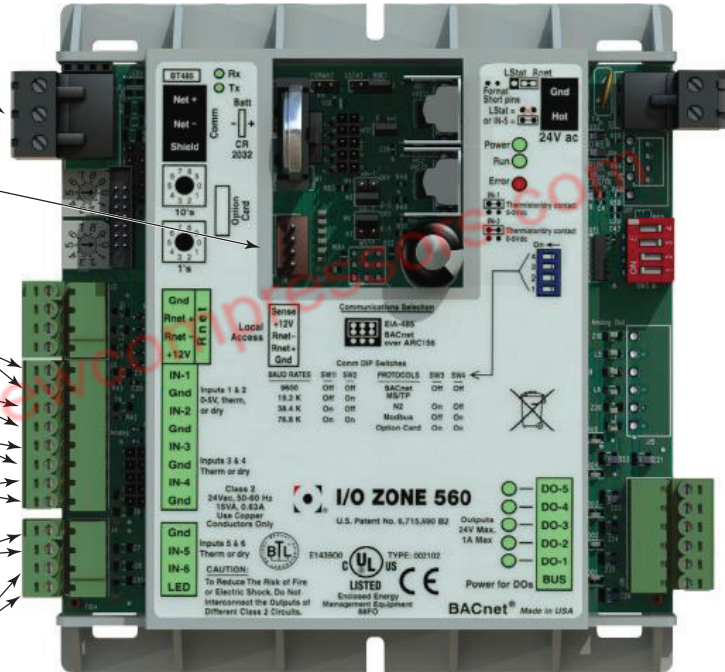

Fig. 22 — Paragon Control Module (PCM)

5.3.4 Slide Valve Capacity Control

The PCM will have the ability to control the compressor slide valve for capacity control by loading/unloading the compressor to maintain the refrigeration system's process control set point. The set point can be defined in one of two ways: refrigerant suction pressure (psig) or a leaving water temperature (deg. F). The end user will have to configure the PCM in the following way:

1. Select Pressure or Temperature for the process control variable (default is Pressure).
2. Select Physical Input or Network Input (Network Input means the process control variable is not physically wired to the PCM, but the value is being passed via the network to the PCM as an input).

3. Input the process control set point value.
 - Allowable pressure range is -1.5 psig to 70 psig (-0.1 bar to 4.8 bar).
 - Allowable temperature range is -60 F to 80 F (-51 C to 27 C).
4. Steps 1, 2, 3 can be accomplished through:
 - Using the BACview hand-held display unit.
 - Downloading BACview software to a laptop.
 - Setting up a communication port between the PCM and System Controller.

The PCM slide valve control logic works with two upper and two lower deadbands. The lower and upper deadbands are adjustable control inputs to customize the capacity control algorithm per the application.

www.carrierscrewcompressors.com

PCM Slide Valve Control Logic

The PCM slide valve control logic works with two upper and two lower deadbands. The lower and upper deadbands are adjustable control inputs to customize the capacity control algorithm per the application. The numbered phases below correspond with those that appear in Fig. 23.

1. On Process Point rise above the **Upper DB-1** deadband, the PCM will energize both unloader coils to load the compressor and increase capacity until the process point falls below **Upper DB-2**.

Slide Valve Coil #1—Energized

Slide Valve Coil #2 —Energized

2. If the Process Point decreases to the **Upper DB-2** deadband limit, the PCM will stop the compressor from loading by de-energizing coil #1, fixing the slide valve position and keeping the compressor capacity constant.

Slide Valve Coil #1—De-energized

Slide Valve Coil #2 —Energized

NOTE: As long as the Process Point remains between the **Upper DB-2** and **Lower DB-3** deadband limits, the slide valve will not move, but remain fixed, keeping the compressor capacity constant.

Slide Valve Coil #1—De-energized

Slide Valve Coil #2 —Energized

3. If the Process Point continues to fall and reaches the **Lower DB-4** deadband limit, the PCM will de-energize both unloader coils to unload the compressor and decrease compressor capacity.

Slide Valve Coil #1—De-energized

Slide Valve Coil #2 —De-energized

4. Both unloader coils will remain De-energized until the suction pressure rises to the **Lower DB-3** deadband limit. This will stop compressor unloading, stopping the slide valve from moving and keeping the compressor capacity constant.

SV Coil #1—De-energized

SV Coil #2 —Energized

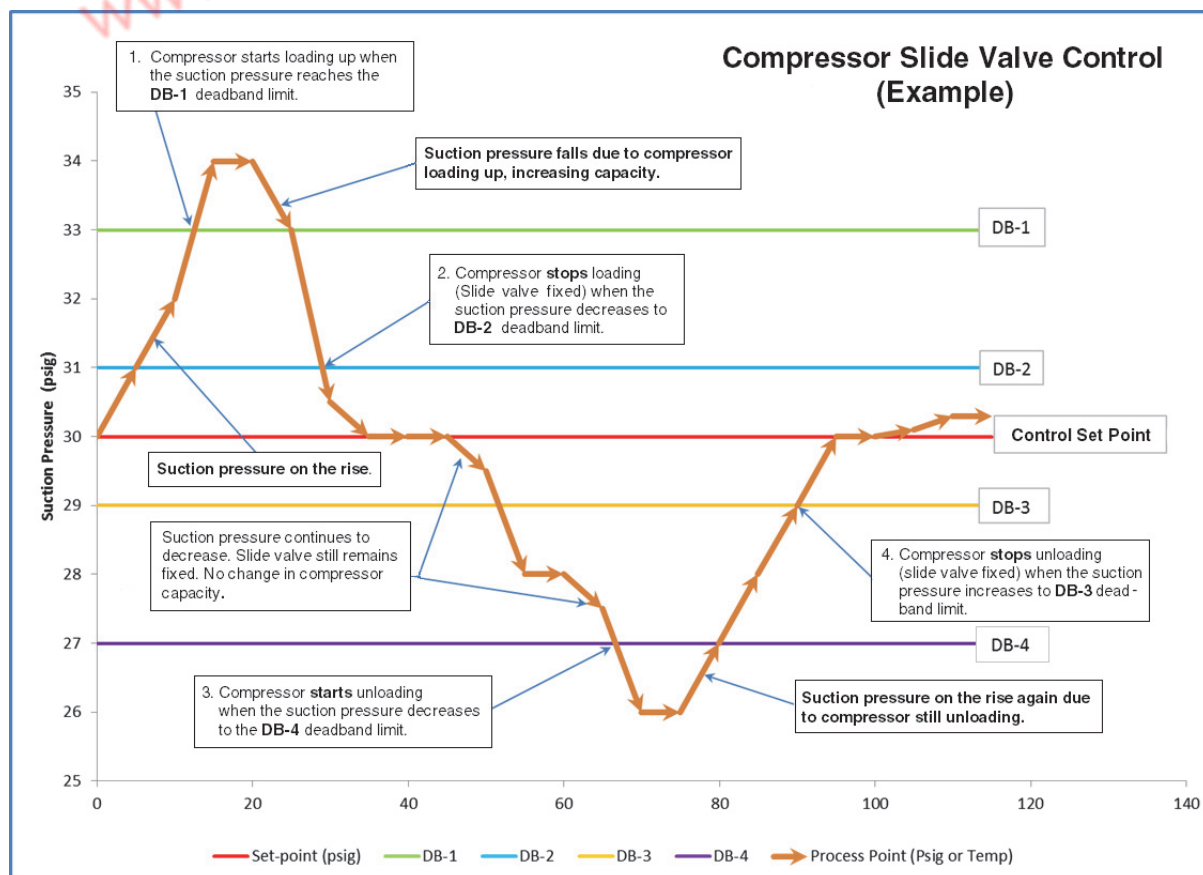

Fig. 23 — Paragon Slide Valve Control Illustration

LEGEND
DB — Deadband

5.3.5 Compressor Protection

Motor and discharge temperature control for a screw compressor is critical. Excessive motor and discharge gas temperatures can cause premature compressor failure; therefore, control of these temperatures is very important. The PCM monitors these temperatures through the use of the factory-installed 5K thermistor in the motor windings and a field-installed 5K thermistor in the compressor discharge temperature thermo-well. When the thermistors indicate an overheated condition, the PCM will perform the following:

- Energize a liquid injection valve, sending cool liquid into the motor compartment.
- Override the Slide Valve and restrict the compressor from unloading and or force the compressor to fully load to reduce motor and or discharge temperature.
- Trip the compressor off.

Motor Temperature (Tm) will have the following functions.

- Control a motor cooling valve to provide liquid injection to the motor compartment.
- Override the compressor slide valve to reduce motor temperature.
- Turn the compressor off on an overheated motor temperature condition.
- See Table 10: Motor and Discharge Temperature Control Points and Table 11: Slide Valve Override Control Points for Tm control points.

Motor Temperature (Td) will have the following functions.

- Override the compressor slide valve to reduce discharge temperature.
- Turn the compressor off on a high discharge temperature condition.
- See Table 10: Motor and Discharge Temperature Control Points and Table 11: Slide Valve Override Control Points for Td control points.

Table 10: Motor and Discharge Temperature Control Points

ALC CONTROLLER	INJECTION ON (°F)	INJECTION OFF (°F)	SHUTDOWN COMPRESSOR (°F)	MANUALLY RESET COMPRESSOR (°F)	TIME DELAY REQUIRED BEFORE MANUAL RESET (SEC)
Discharge Temperature (Td)	NA	NA	Td > 225	Td < 175	30
Motor Cooling Temperature (Tm)	Tm > 240	Tm < 225	Tm > 270	Tm < 225	30

Table 11: Slide Valve Override Control Points

ALC CONTROLLER	RESTRICT FURTHER COMPRESSOR UNLOADING Energize SV Coil #2 Continuously (°F)	FULLY LOAD COMPRESSOR AND RESTRICT UNLOADING BELOW 100% Energize SV Coil #1 and Coil #2 Continuously (°F)
SV – Discharge Temperature (Td)	200 < Td < 215 (discontinue SV override when Td < 198)	Td > 215 (discontinue SV override when Td < 213)
SV – Motor Cooling Temperature (Tm)	245 < Tm < 260 (discontinue SV override when Tm < 243)	Tm > 260 (discontinue SV override when Tm < 258)

LEGEND

SV — Slide Valve

5.3.6 LED Fault Indication

The PCM will provide an LED alarm output signal to the System Controller when a compressor fault condition arises.

FAULT DESCRIPTION	LED INDICATION (OUTPUT#4)	OUTPUT #5	COMPRESSOR	MANUAL RESET REQUIRED
High Discharge Temperature Trip	Solid red	Opens/De-energized	OFF	Yes
High Motor Temperature Trip	Constant blinking	Opens/De-energized	OFF	Yes
Compressor Oil Trip	One blink and 2-second pause	Opens/De-energized	OFF	Yes
Faulty Transducer/ Thermistor Slide Valve Sensor	One blink and 2-second pause	Opens/De-energized	OFF	Yes
Faulty Motor Temperature Thermistor	Three blinks and 2-second pause	Opens/De-energized	OFF	Yes
Faulty Discharge Temperature Thermistor	Four blinks and 2-second pause	Opens/De-energized	OFF	Yes

5.3.7 PCM Controller Display Features

The PCM can be displayed using various tools to configure and setup the controller for the application. The PCM inputs, outputs, status, and fault codes can be viewed by the end user via the following accessory items:

- BACview6 Handheld (Portable or Permanent install).
- BACview6 Software (Virtual BACview6 Handheld using a Laptop).

BACview6 Handheld Display

The BACview6 handheld device (see Fig. 24) connects directly to the four-pin connection port on the PCM controller. This tool is portable and ideal for technicians to quickly set up and/or evaluate the status of the compressor's operating mode. See the BACview User Guide manual for specific operating instruction on the handheld device.



Fig. 24 — BACview6 Handheld Display

BACview6 Virtual Display

The virtual BACview software (see Fig. 25) simulates the BACview6 Handheld keypad and display. It has all the same functionality as the BACview6 device except that it is a software-based application that is easily displayed on any laptop.



Fig. 25 — BACview6 Laptop Display

Once the software is installed, the user will use the 12-ft interface cable (Carlyle Part# USB-L) to communicate between the laptop and the PCM. See Fig. 26. This is also covered in the BACview User Guide.

Connect the USB-Link to the computer and to the controller's **Local Access** port.

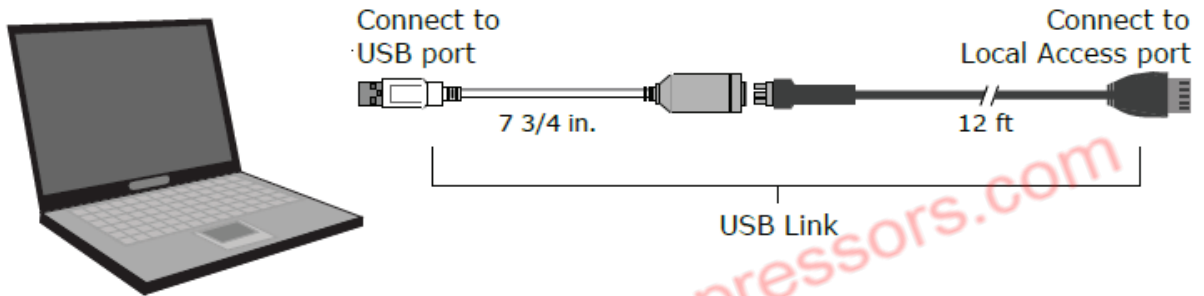

Fig. 26 — Laptop-to-BACview6 Connection Schematic

5.3.8 General Installation

The PCM can mount directly inside the compressor's electrical box as shown in Fig. 27.

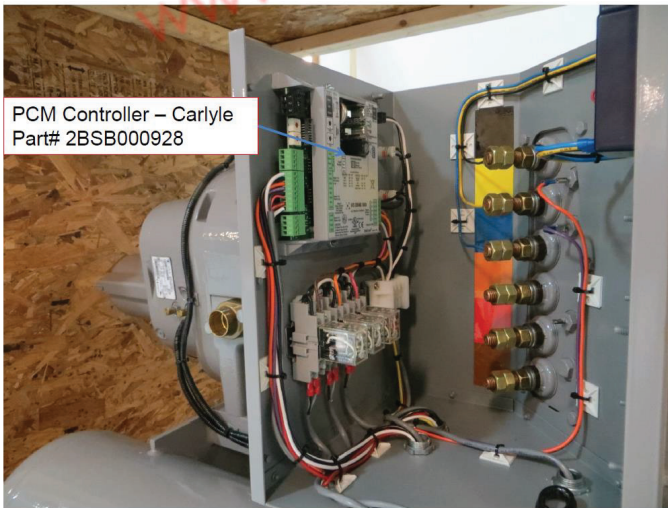

Fig. 27 — PCM Mounted inside Compressor Box

6.0 Compressor Design Pressures

6.1 Compressor Requirements

The compressor is designed to meet the UL and ASHRAE safety code for refrigeration compressors. The manufacturing facilities for the compressor conduct pressure burst tests in accordance with ASHRAE-15, UL safety codes, and the Pressure Equipment 97/23/CEE directive.

6.2 Design Pressures

Pressure Relief Valve

The internal relief valve is designed to open when the pressure differential between suction and discharge pressure is greater than 27.6 bar (400 psid) for R-134a and greater than 30 bar (435 psid) for R-404A. The valve will close and seal again after the pressure difference falls below the set value.

Hydrostatic Design Pressures

The design pressures for the compressor castings are listed in Table 12.

Table 12: Compressor Design Pressures

PRESSURE TYPE	APPLICATION	DISCHARGE	ECONOMIZER	SUCTION
Hydrostatic Burst Test Pressure (BURST)	R-134a Water-Cooled	950 psig (6.6 MPa)	540 psig (3.7 MPa)	440 psig (3.0 MPa)
	R-134a Air-Cooled	1470 psig (10.1 MPa)	610 psig (4.2 MPa)	440 psig (3.0 MPa)
	R-404A LT Ref	1770 psig (12.2 MPa)	1040 psig (7.2 MPa)	870 psig (6.0 MPa)
Proof Test Pressure (TP)	R-134a Water-Cooled	465 psig (3.2 MPa)		
	R-134a Air-Cooled			
	R-404A LT Ref			
Maximum Operating Pressure (MOP)	R-134a Water-Cooled	190 psig (1.3 MPa)	108 psig (0.7 MPa)	61 psig (0.4 MPa)
	R-134a Air-Cooled	294 psig (2.0 MPa)	122 psig (0.8 MPa)	51 psig (0.4 MPa)
	R-404A LT Ref	354 psig (2.4 MPa)	116 psig (0.8 MPa)	38 psig (0.3 MPa)
Leak Test Pressure (AP)	R-134a Water-Cooled	310 psig (2.1 MPa)		
	R-134a Air-Cooled			
	R-404A LT Ref			
UL60335-2-34 Design Pressure (DP)	R-134a Water-Cooled	190 psig (1.3 MPa)	108 psig (0.7 MPa)	88 psig (0.6 MPa)
	R-134a Air-Cooled	294 psig (2.0 MPa)	122 psig (0.8 MPa)	88 psig (0.6 MPa)
	R-404A LT Ref	354 psig (2.4 MPa)	116 psig (0.8 MPa)	176 psig (1.2 MPa)

LEGEND

LT — Low Temperature Refrigeration

NOTE: All pressures listed are gage pressures. Add 14.7 psi (0.1 MPa) to obtain absolute pressure, if necessary.

7.0 Variable Frequency Drive Guidelines

7.1 Scope

Carlyle has conducted an extensive qualification program for our R-134a compressors and has approved most compressors for VFD applications. A summary of the qualified models is presented in the table below.

Table 13: Variable Speed Model Summary

MODEL NUMBER	APPROVED FOR VARIABLE SPEED	
	AIR-COOLED	WATER-COOLED ³
06TS-137	Note 1 and 2	N/A
06TS-155	YES	N/A
06TS-186	YES	N/A
06TT-266	YES	Note 1 and 3
06TT-301	YES	Note 1 and 3
06TT-356	YES	Note 1 and 3
06TU-483	YES	YES, Note 3
06TU-554	YES	YES, Note 3
06TV-680	YES	YES, Note 3
06TV-753	Note 2	YES, Note 3
06TV-819	YES	Note 2 and 3

NOTES:

1. See Application Engineering, as approval is limited to certain applications.
2. See Application Engineering, as compressor has been approved, but limited performance data are available.
3. Standard model cannot be used for VFD applications. The VS model must be ordered, which is identified by an X in the 5th digit of the model number.
4. Variable speed operation has not been approved for low/medium temperature R-404A, R-407A, R-407C, R-407F, and R-507A compressors.

It may be possible to have the drive provide the compressor motor protection, replacing the compressor overloads. Carlyle Application Engineering should be contacted to verify that the overcurrent protection meets Carlyle's requirements for UL-rated motor overload protection and to verify the required overload settings.

It is important to work with the drive manufacturer to select a drive appropriate for the application. Refrigeration screw compressors provide a constant torque loading to the drive and also have unique starting torque requirements. The drive should not be sized on the nominal HP rating of the compressor, but based on the nominal electrical data, including RLA and LRA (available in Section 8.3), along with the operating power and amperage at the max load design condition. It is important that the appropriate criteria are taken into consideration when selecting the type and size of the drive.

It is also important to review items associated with the wiring of the compressor and associated control system wiring, as special precautions may be required to avoid interference between the drive and other control wiring. There may also be restrictions on the length and routing of the wires from the drive to the compressor. These

items should be reviewed with the drive manufacturer to ensure all application guidelines are followed when installing the drive.

7.2 Capacity Control

The compressors have been approved with an allowable speed range from 30 to 60 Hz. The capacity at 30 Hz will be approximately 50% of the full load capacity and will vary linearly in direct proportion to the speed.

It is possible to operate the compressors with a combination of slide valve and VFD control. The compressor can be operated at minimum speed of 30 Hz and the slide valve used for further unloading as long as appropriate discharge and motor temperature limits are observed. The solenoid valve is controlled exactly the same way as without the VFD. The compressor can be unloaded, either with the VFD or the slide valve, as long as discharge and motor temperature requirements are met.

Discharge Temperature

1. Compressor must be forced to 100% load if discharge temperature ≥ 200 F (93.3 C).
2. Unloading control must limit further unloading if discharge temperature ≥ 190 F (87.8 C)

Motor Temperature

1. Compressor must be forced to 100% load if motor temperature ≥ 265 F (129.4 C).
2. Unloading control must limit further unloading if motor temperature ≥ 260 F (126.7 C)

NOTE: Different temperature limits may be required, depending on the accuracy and response time of the sensors and control system that are used, as well as the overall stability of the system and desired safety factor.

7.3 Power Supply

The variable speed drive should fix the output voltage based on a constant Volts-per-Hz curve running through the nominal voltage (380V/60Hz, 460V/60Hz), regardless of the nominal voltage supplied to the drive. The drive should maintain a constant V-Hz over the range of operation and should limit the speed of the drive if the appropriate voltage cannot be maintained. Overvoltage should be limited to +10% and under voltage limited to -15%. Undervoltage should limit the speed (Hz) until the constant V-Hz curve is reached. Overvoltage should limit operation at the maximum speed, 60 Hz. The VFD should also limit the amperage of the compressor to $\geq 90\%$ of the MCC (maximum continuous current) value (lower amperage limits may be applied depending on the application). It may be necessary to limit the speed of the

compressor at high-load conditions, especially if operating below the nominal voltage.

Figure 28 shows two sample voltage curves showing compressor motor voltage (V) versus operating speed

(Hz). As shown in the graph, the motor voltage is lowered at lower operating speeds while maintaining a fixed Volts/Hz value.

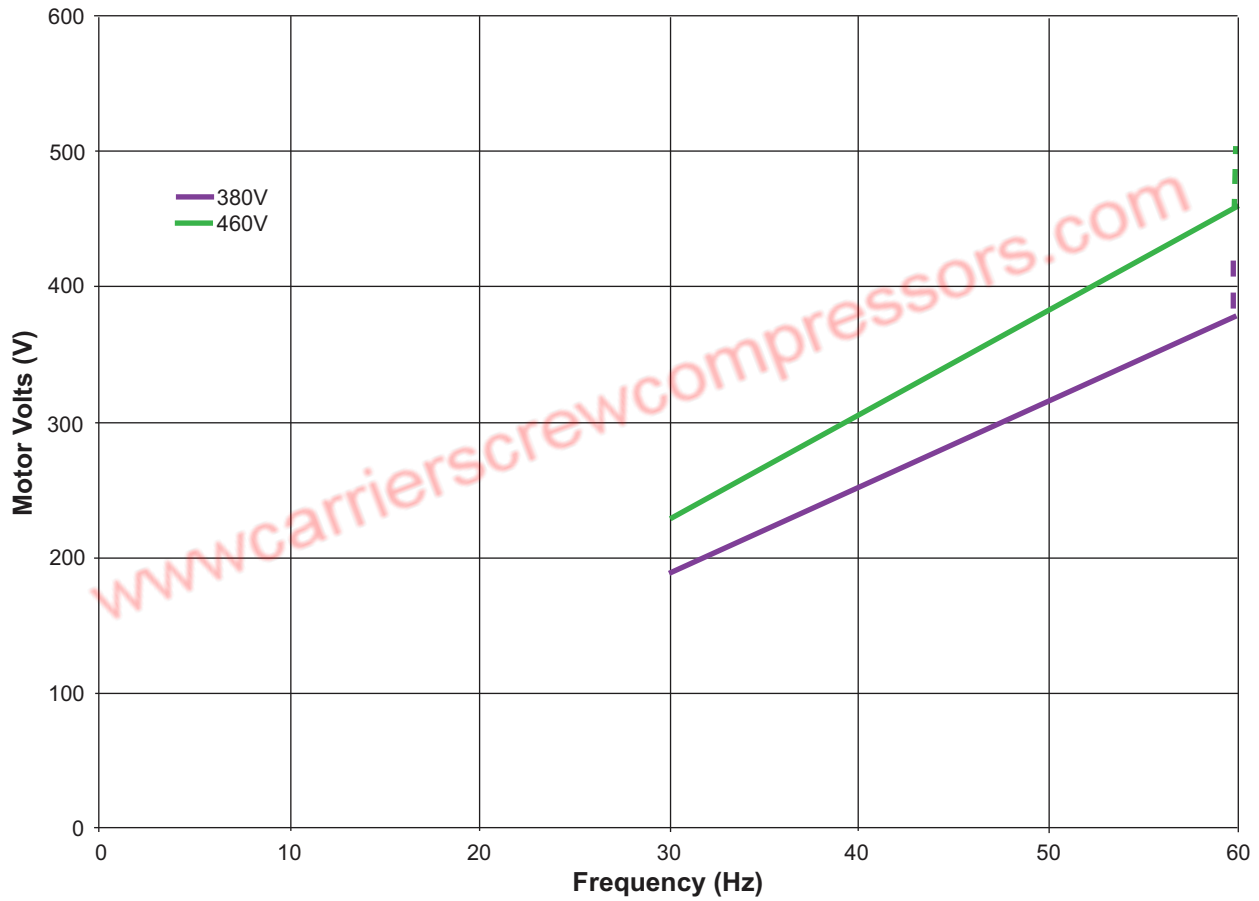

Fig. 28 — Sample Compressor Motor Voltage Curves

8.0 Compressor Electrical Data

8.1 Allowable Voltage Range

The motors for the Paragon compressor are designed to function in the voltage ranges listed in Table 14.

Table 14: Compressor Motor Voltage Range

VOLTAGE CODE	60 Hz			50 Hz		
	NOMINAL	MIN	MAX	NOMINAL	MIN	MAX
S	460	396	506	400	342	440
				690*	592	762
T	575	518	633	—	—	—
W	380	342	418	—	—	—
	690*	592	762			
X	230	198	253	200	180	220
Z	200	180	220	—	—	—

* For Wye connected motors only.

8.2 Electrical Connection Requirements

Power Connections

The compressor terminals are copper feed-through pins with M12 metric threads for all models (except for low-voltage versions of the 06TU and 06TV model types, which have M16 metric threads).

Torque specifications are as follows:

- 15 to 20 lb-ft (20-27 Nm) on the TS, TT, TU, and TV compressors with 12 mm pins
- 20 to 25 lb-ft (27-34 Nm) on low voltage (< 375 V) TU and TV compressors with 16 mm pins

Power wires are connected to the terminal pins using ring terminals and jam nuts. The power connection system is designed for nominal line voltages up to 575 volts. The motor temperature thermistors and a separate 12 mm grounding lug connection are located in the terminal pin area. Terminal and sensor pin layout on the compressor is shown in Fig. 29 and Fig. 30.

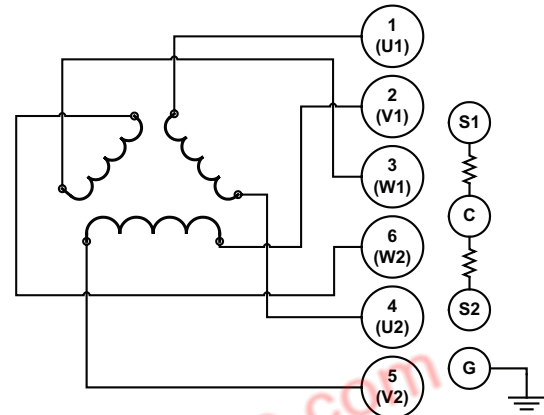

Fig. 29 — Terminal and Sensor Pin Layout

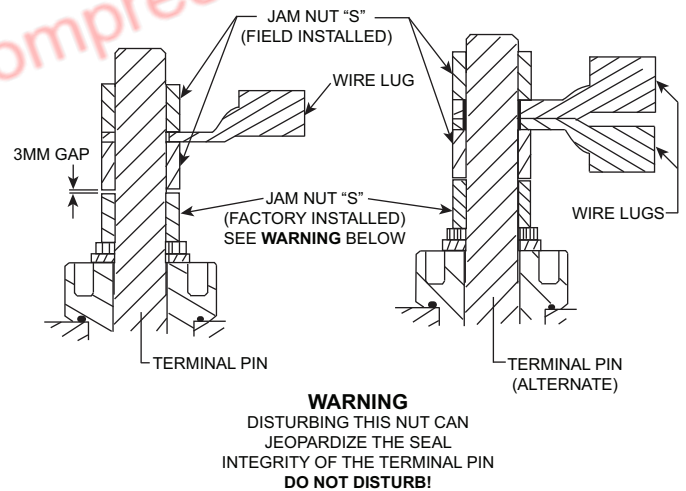

Fig. 30 — Terminal Pin Cross Section

The Paragon compressor is approved for use with across-the-line and open and closed transition wye-delta applications.

Across-the-Line Starting

The table below shows the wiring configuration for an across-the-line (XL) delta configuration.

Table 15: Across-the-Line, Delta Configuration Wiring

CONNECTION	L1	L2	L3	TIE TOGETHER
Start (delta)	1, 6 (U1, W2)	2, 4 (V1, U2)	3, 5 (W1, V2)	—
Run (delta) (same as start)	1, 6 (U1, W2)	2, 4 (V1, U2)	3, 5 (W1, V2)	—

Wye-Delta Starting (Open Transition)

There are two critical timing parameters associated with starting the Paragon compressor with an open transition wye-delta starter. The first is the maximum duration of running in the wye connection. It is recommended that the duration of the wye connection be 5 seconds. The duration of the wye connection can be longer but in no case should exceed 10 seconds. This is necessary to limit the potential for excessive heating of the motor.

The second critical timing parameter is the duration of the power interruption from when the wye connection is broken to when the delta connection is made. It is recommended that the duration of this interruption not exceed the values given in Table 16 for single compressor circuits. A shorter duration may be required if compressor must start against head pressure. Starter selections should be made such that this limit is not exceeded. Longer interruption times could lead to excessive deceleration during the power interruption. Low running speed at transition will result in inrush currents similar to the delta locked rotor current.

Table 16: Maximum Transition Time

MODEL	MAXIMUM TRANSITION TIME
TS	0.035 seconds
TT	0.055 seconds
TU	0.060 seconds
TV	0.060 seconds

The table below shows the wiring configuration for an open transition wye-delta start configuration.

Table 17: Wye-Delta Start Configuration Wiring

CONNECTION	L1	L2	L3	TIE TOGETHER
Start (wye) (5 sec)	1 (U1)	2 (V1)	3 (W1)	4, 5, 6 (U2, V2, W2)
Run (delta)	1, 6 (U1, W2)	2, 4 (V1, U2)	3, 5 (W1, V2)	—

Motor Windings Thermistor

The motor winding thermistor is embedded directly into the windings of the motor. The thermistor is an NTC type with a standard resistance of 5000 ohms at 77 F (25 C). All Paragon compressor motors are supplied with a spare thermistor to be used if the primary thermistor fails. Table 18 lists the resistance versus temperature characteristics. Additional information regarding this sensor can be obtained from Carlyle Application Engineering.

Table 18: Resistance vs Temperature

TEMPERATURE			RESISTANCE
C	±C	F	ohms
-30	.35	-22	88480.0
-25	.33	-13	65205.0
-20	.30	-4	48536.0
-15	.28	5	36476.0
-10	.20	14	27663.0
-5	.20	23	16325.0
5	.20	41	12696.0
10	.20	50	9949.5
15	.20	59	7855.5
20	.20	68	6246.0
25	.20	77	5000.0
30	.20	86	4028.4
35	.20	95	3265.7
40	.20	104	2663.2
45	.20	113	2184.2
50	.20	122	1801.2
55	.20	131	1493.1
60	.20	140	1243.9
65	.20	149	1041.4
70	.20	158	875.8
75	.23	167	739.7
80	.26	176	627.6
85	.29	185	534.9
90	.32	194	457.7
95	.35	203	393.3
100	.38	212	339.3
105	.41	221	293.8
110	.44	230	255.3
115	.47	239	222.6
120	.50	248	194.8

8.3 Motor Data

Air-Cooled Motor Data R-134a

COMPRESSOR BASE MODELS	MOTOR SIZE (HP AT 60 Hz)	MOTOR VOLTAGE (VOLTS-PH-FREQ)	RLA	LRA	
				WYE	DELTA
06TSA137	60	460-3-60	89	162	505
		400-3-50	86	160	500
		690-3-50	50	289	NOTE 2
		575-3-60	68	130	404
		380-3-60	103	196	611
		690-3-60	59	353	NOTE 2
		230-3-60	178	324	1010
		200-3-50	163	320	1000
		200-3-60	196	373	1162
06TSA155	75	460-3-60	100	174	545
		400-3-50	96	170	530
		690-3-50	58	306	NOTE 2
		575-3-60	76	139	436
		380-3-60	116	211	660
		690-3-60	67	381	NOTE 2
		230-3-60	200	348	1090
		200-3-50	183	340	1060
		200-3-60	220	400	1254
06TSA186	75	460-3-60	116	174	545
		400-3-50	112	170	530
		690-3-50	65	306	NOTE 2
		575-3-60	89	139	436
		380-3-60	135	211	660
		690-3-60	78	381	NOTE 2
		230-3-60	233	348	1090
		200-3-50	213	340	1060
		200-3-60	256	400	1254
06TTA266	120	460-3-60	165	298	930
		400-3-50	159	303	945
		690-3-50	92	546	NOTE 2
		575-3-60	126	238	744
		380-3-60	191	361	1126
		690-3-60	105	650	NOTE 2
		230-3-60	330	596	1860
		200-3-50	303	606	1890
		200-3-60	363	685	2139
06TTA301	150	460-3-60	187	382	1190
		400-3-50	181	388	1210
		690-3-50	105	699	NOTE 2
		575-3-60	143	306	952
		380-3-60	217	462	1441
		690-3-60	120	832	NOTE 2
		230-3-60	375	764	2380
		200-3-50	344	776	2420
		200-3-60	412	879	2737

LEGEND

FREQ — Frequency
HP — Horsepower
LRA — Locked Rotor Amps
PH — Phase
RLA — Rated Load Amps

NOTES:

1. Please contact Carlyle Application Engineering for proper motor protection device.
2. Delta wiring is not applicable for the selected voltage.

Air-Cooled Motor Data R-134a (cont)

COMPRESSOR BASE MODELS	MOTOR SIZE (HP AT 60 Hz)	MOTOR VOLTAGE (VOLTS-PH-FREQ)	RLA	LRA	
				WYE	DELTA
06TTA356	150	460-3-60	226	382	1190
		400-3-50	218	388	1210
		690-3-50	126	699	NOTE 2
		575-3-60	173	306	952
		380-3-60	262	462	1441
		690-3-60	144	832	NOTE 2
		230-3-60	452	764	2380
		200-3-50	414	776	2420
		200-3-60	497	879	2737
06TUA483	225	460-3-60	314	578	1800
		400-3-50	303	587	1828
		690-3-50	175	1055	NOTE 2
		575-3-60	240	462	1440
		380-3-60	363	700	2179
		690-3-60	200	1258	NOTE 2
		230-3-60	628	1156	3600
		200-3-50	576	1174	3656
		200-3-60	691	1329	4140
06TUA554	225	460-3-60	360	578	1800
		400-3-50	347	587	1828
		690-3-50	201	1055	NOTE 2
		575-3-60	275	462	1440
		380-3-60	417	700	2179
		690-3-60	230	1258	NOTE 2
		230-3-60	720	1156	3600
		200-3-50	660	1174	3656
		200-3-60	792	1329	4140
06TVA680	340	460-3-60	462	623	1900
		400-3-50	438	629	1919
		690-3-50	555	1108	NOTE 2
06TVA753	340	460-3-60	506	623	1900
		400-3-50	487	629	1919
		690-3-50	579	1108	NOTE 2
06TVA819	340	460-3-60	517	623	1900
		400-3-50	504	629	1919
		690-3-50	571	1108	NOTE 2

LEGEND

FREQ — Frequency
HP — Horsepower
LRA — Locked Rotor Amps
PH — Phase
RLA — Rated Load Amps

NOTES:

1. Please contact Carlyle Application Engineering for proper motor protection device.
2. Delta wiring is not applicable for the selected voltage.

Water-Cooled Motor Data R-134a

COMPRESSOR BASE MODELS	MOTOR SIZE (HP AT 60 Hz)	MOTOR VOLTAGE (VOLTS-PH-FREQ)	RLA	LRA	
				WYE	DELTA
06TTW266	90	460-3-60	124	229	715
		400-3-50	120	233	726
		690-3-50	69	419	NOTE 2
		575-3-60	95	183	572
		380-3-60	144	277	866
		690-3-60	83	500	NOTE 2
		230-3-60	249	458	1430
		200-3-50	228	466	1452
		200-3-60	274	527	1645
06TTW301	90	460-3-60	139	229	715
		400-3-50	134	233	726
		690-3-50	77	419	NOTE 2
		575-3-60	106	183	572
		380-3-60	161	277	866
		690-3-60	89	500	NOTE 2
		230-3-60	278	458	1430
		200-3-50	255	466	1452
		200-3-60	306	527	1645
06TTW356	120	460-3-60	161	298	930
		400-3-50	155	303	945
		690-3-50	90	546	NOTE 2
		575-3-60	123	238	744
		380-3-60	186	361	1126
		690-3-60	107	650	NOTE 2
		230-3-60	322	596	1860
		200-3-50	295	606	1890
		200-3-60	354	685	2139
06TUW483	160	460-3-60	199	408	1270
		400-3-50	186	414	1290
		690-3-50	108	745	NOTE 2
		575-3-60	159	326	1016
		380-3-60	240	494	1537
		690-3-60	132	888	NOTE 2
		230-3-60	397	816	2540
		200-3-50	371	828	2580
		200-3-60	457	938	2921

LEGEND

FREQ — Frequency
HP — Horsepower
LRA — Locked Rotor Amps
PH — Phase
RLA — Rated Load Amps

NOTES:

1. Please contact Carlyle Application Engineering for proper motor protection device.
2. Delta wiring is not applicable for the selected voltage.

Water-Cooled Motor Data R-134a (cont)

COMPRESSOR BASE MODELS	MOTOR SIZE (HP AT 60 Hz)	MOTOR VOLTAGE (VOLTS-PH-FREQ)	RLA	LRA	
				WYE	DELTA
06TUW554	160	460-3-60	223	408	1270
		400-3-50	209	414	1290
		690-3-50	121	745	NOTE 2
		575-3-60	179	326	1016
		380-3-60	270	494	1537
		690-3-60	149	888	NOTE 2
		230-3-60	447	816	2540
		200-3-50	417	828	2580
		200-3-60	514	938	2921
06TVW680	225	460-3-60	280	578	1800
		400-3-50	261	587	1828
		690-3-50	151	1055	NOTE 2
		575-3-60	224	462	1440
		380-3-60	338	700	2179
		690-3-60	186	1258	NOTE 2
		230-3-60	559	1156	3600
		200-3-50	522	1174	3656
		200-3-60	643	1329	4140
06TVW753	225	460-3-60	310	578	1800
		400-3-50	289	587	1828
		690-3-50	168	1055	NOTE 2
		575-3-60	248	462	1440
		380-3-60	375	700	2179
		690-3-60	206	1258	NOTE 2
		230-3-60	619	1156	3600
		200-3-50	579	1174	3656
		200-3-60	712	1329	4140
06TVW819	225	460-3-60	330	578	1800
		400-3-50	308	587	1828
		690-3-50	179	1055	NOTE 2
		575-3-60	264	462	1440
		380-3-60	400	700	2179
		690-3-60	220	1258	NOTE 2
		230-3-60	660	1156	3600
		200-3-50	617	1174	3656
		200-3-60	759	1329	4140

LEGEND

FREQ — Frequency
HP — Horsepower
LRA — Locked Rotor Amps
PH — Phase
RLA — Rated Load Amps

NOTES:

1. Please contact Carlyle Application Engineering for proper motor protection device.
2. Delta wiring is not applicable for the selected voltage.

Low Temperature Motor Data

COMPRESSOR BASE MODELS	MOTOR SIZE (HP AT 60 Hz)	MOTOR VOLTAGE (VOLTS-PH-FREQ)	RLA					LRA	
			404A	407A	407C	407F	507A	WYE	DELTA
06TSR137	60	400-3-50	98	80	76	87	100	160	500
		460-3-60	101	90	85	123	106	162	505
		690-3-50	57	46	44	50	58	289	NOTE 2
		575-3-60	78	72	68	99	85	130	404
		380-3-60	117	109	103	149	128	196	611
		690-3-60	67	60	57	82	71	353	NOTE 2
		200-3-50	186	159	153	174	200	320	1000
		230-3-60	203	180	171	247	212	324	1010
		200-3-60	223	206	196	284	244	373	1162
06TSR155	75	400-3-50	108	87	84	118	108	170	530
		460-3-60	119	97	93	146	113	174	545
		690-3-50	72	51	49	69	63	306	NOTE 2
		575-3-60	82	77	74	117	90	139	436
		380-3-60	126	117	112	176	137	211	660
		690-3-60	73	65	62	97	75	381	NOTE 2
		200-3-50	227	175	168	237	216	340	1060
		230-3-60	217	194	185	291	226	348	1090
		200-3-60	239	223	213	335	260	400	1254
06TSR186	75	400-3-50	120	102	96	151	122	170	530
		460-3-60	124	113	107	176	129	174	545
		690-3-50	69	59	49	87	71	306	NOTE 2
		575-3-60	95	90	74	140	103	139	436
		380-3-60	144	136	112	213	156	211	660
		690-3-60	73	75	62	117	86	381	NOTE 2
		200-3-50	227	204	168	301	244	340	1060
		230-3-60	249	225	185	351	258	348	1090
		200-3-60	273	259	213	404	297	400	1254
06TTR266	120	400-3-50	183	165	159	213	185	303	945
		460-3-60	190	179	171	239	195	298	930
		690-3-50	106	95	92	123	107	546	NOTE 2
		575-3-60	145	143	137	191	156	238	744
		380-3-60	220	216	207	289	236	361	1126
		690-3-60	121	119	114	159	130	650	NOTE 2
		200-3-50	349	329	317	426	370	606	1890
		230-3-60	380	357	342	477	390	596	1860
		200-3-60	418	411	393	549	449	685	2139

LEGEND

FREQ — Frequency
HP — Horsepower
LRA — Locked Rotor Amps
PH — Phase
RLA — Rated Load Amps

NOTES:

1. Please contact Carlyle Application Engineering for proper motor protection device.
2. Delta wiring is not applicable for the selected voltage.

Low Temperature Motor Data (cont)

COMPRESSOR BASE MODELS	MOTOR SIZE (HP AT 60 Hz)	MOTOR VOLTAGE (VOLTS-PH-FREQ)	RLA					LRA	
			404A	407A	407C	407F	507A	WYE	DELTA
06TTR301	150	400-3-50	203	185	180	218	205	388	1210
		460-3-60	210	199	193	249	215	382	1190
		690-3-50	118	107	104	127	119	699	NOTE 2
		575-3-60	160	159	154	199	172	306	952
		380-3-60	243	240	233	301	260	462	1441
		690-3-60	135	132	129	166	143	832	NOTE 2
		200-3-50	386	369	360	437	410	776	2420
		230-3-60	421	397	386	497	430	764	2380
		200-3-60	462	457	443	572	495	879	2737
06TTR356	150	400-3-50	229	211	203	260	231	388	1210
		460-3-60	238	227	218	284	243	382	1190
		690-3-50	132	122	118	151	134	699	NOTE 2
		575-3-60	182	181	174	227	194	306	952
		380-3-60	275	274	263	344	294	462	1441
		690-3-60	151	151	145	189	162	832	NOTE 2
		200-3-50	435	422	407	521	462	776	2420
		230-3-60	475	453	435	568	486	764	2380
		200-3-60	523	521	500	653	559	879	2737

LEGEND

FREQ — Frequency
HP — Horsepower
LRA — Locked Rotor Amps
PH — Phase
RLA — Rated Load Amps

NOTES:

1. Please contact Carlyle Application Engineering for proper motor protection device.
2. Delta wiring is not applicable for the selected voltage.

Medium Temperature Motor Data

COMPRESSOR BASE MODELS	MOTOR SIZE (HP AT 60 Hz)	MOTOR VOLTAGE (VOLTS-PH-FREQ)	RLA					LRA	
			404A	407A	407C	407F	507A	WYE	DELTA
06TSM137	75	400-3-50	111	91	86	99	113	170	530
		460-3-60	123	110	104	150	129	174	545
		690-3-50	65	52	50	57	66	306	NOTE 2
		575-3-60	99	91	86	126	108	139	436
		380-3-60	149	139	131	190	163	211	660
		690-3-60	82	73	70	100	87	381	NOTE 2
		200-3-50	223	191	183	209	240	340	1060
		230-3-60	246	218	207	299	257	348	1090
		200-3-60	283	261	249	360	310	400	1254
06TSM155	75	400-3-50	118	95	92	129	118	170	530
		460-3-60	126	103	98	155	120	174	545
		690-3-50	68	48	46	65	60	306	NOTE 2
		575-3-60	101	95	91	144	111	139	436
		380-3-60	152	141	135	212	165	211	660
		690-3-60	84	75	71	112	86	381	NOTE 2
		200-3-50	235	181	174	245	224	340	1060
		230-3-60	252	225	215	338	262	348	1090
		200-3-60	290	271	258	406	315	400	1254
06TTM266	150	400-3-50	216	195	188	251	218	388	1210
		460-3-60	228	215	205	287	234	382	1190
		690-3-50	125	112	108	145	126	699	NOTE 2
		575-3-60	183	180	173	241	197	306	952
		380-3-60	276	271	260	363	296	462	1441
		690-3-60	152	149	143	200	163	832	NOTE 2
		200-3-50	433	408	393	529	459	776	2420
		230-3-60	456	428	410	572	468	764	2380
		200-3-60	525	516	494	690	564	879	2737
06TTM301	150	400-3-50	217	198	192	233	219	388	1210
		460-3-60	228	216	210	270	233	382	1190
		690-3-50	126	114	111	136	127	699	NOTE 2
		575-3-60	183	182	176	228	197	306	952
		380-3-60	276	273	265	342	295	462	1441
		690-3-60	152	149	145	187	161	832	NOTE 2
		200-3-50	434	415	405	491	461	776	2420
		230-3-60	456	430	418	538	466	764	2380
		200-3-60	525	519	503	650	563	879	2737

LEGEND

FREQ — Frequency
HP — Horsepower
LRA — Locked Rotor Amps
PH — Phase
RLA — Rated Load Amps

NOTES:

1. Please contact Carlyle Application Engineering for proper motor protection device.
2. Delta wiring is not applicable for the selected voltage.

9.0 Compressor Accessories

9.1 Oil Separators

9.1.1 Horizontal Oil Separators/Accessories

Compact Over/Under

CARLYLE PART NUMBER	COMPRESSOR USAGE							
	06TS*137	06TS*155	06TS*186	06TT*266	06TT*301	06TT*356	06TU*483	06TU*554
8BSB000643	X	X	X	X	X			
8BTB000644						X	X	X

Side-Mount

CARLYLE PART NUMBER	COMPRESSOR USAGE							
	06TS*137	06TS*155	06TS*186	06TT*266	06TT*301	06TT*356	06TU*483	06TU*554
8BSB000704	X	X	X	X	X			
8BTB000705						X	X	X

Side-Mount

CARLYLE PART NUMBER	COMPRESSOR USAGE		
	06TV*680	06TV*753	06TV*819
8BVB000787	X	X	X

NOTES:

1. One side-mount oil separator or compact over/under oil separator required for each R-134a compressor.
2. Compact horizontal oil separators are intended for close-coupled, DX-type systems.
3. One discharge service flange package required for each compact over/under oil separator (see Section 9.5).

Optical Oil Level Sensor

CARLYLE PART NUMBER	OIL SEPARATOR USAGE				
	8BSB000643	8BTB000644	8BSB000704	8BTB000705	8BVB000787
8CCB000742	X	X	X	X	X

NOTE: One optical oil level sensor and one oil level switch required for each horizontal oil separator.

Optical Oil Level Switch

CARLYLE PART NUMBER	OIL SEPARATOR USAGE				
	8BSB000643	8BTB000644	8BSB000704	8BTB000705	8BVB000787
8CCB000743	X	X	X	X	X

NOTE: One optical oil level sensor and one oil level switch required for each horizontal oil separator.

Flexible-Band Oil Separator Heater

CARLYLE PART NUMBER	OIL SEPARATOR USAGE				
	8BSB000643	8BTB000644	8BSB000704	8BTB000705	8BVB000787
HT38KN007	X	X	X	X	X

NOTE: One heater required for each side mount oil separator or compact horizontal oil separator.

9.1.2 Vertical Oil Separators/Accessories

CARLYLE PART NUMBER	COMPRESSOR USAGE
KH31ZZ212	06TSR, 06TTR, 06TSM, 06TTM (see note below)
KH31ZZ420	
KH31HZ381	
KH31HZ382	
KH31HZ421	
KH31HZ428	

NOTE: Contact Application Engineering for usage information.

Mechanical Oil Level Switch

CARLYLE PART NUMBER	OIL SEPARATOR USAGE
HK13LB004	Vertical Oil Separators

NOTES:

1. Protects compressor against loss of oil in oil separator.
2. The float switch must be wired to open the compressor safety control circuit in cases of low oil level.
3. The switch is rated for 20 va maximum.

Insertable Oil Separator Heater

CARLYLE PART NUMBER	VOLTAGE	WATTS
5H40-381	115 V	200
5H40-391	230 V	200

NOTE: One heater required for each vertical oil separator.

9.2 Compressor Components Kit

CARLYLE PART NUMBER	COMPRESSOR USAGE			
	TS	TT	TU	TV
6BSA000320	X			
6BTA000321		X		
6BUA000322			X	
6BVA000804				X

NOTES:

1. One kit required for each compressor ordered.
2. Contact Carlyle Applications Engineering for proper kit.

Compressor component kit contains following items:

6BSA000320

- (1) Terminal Box Kit (P/N 6BTA000323)
- (1) Jam Nut Kit (P/N 6BTA000318)
- (1) Oil Supply Tubing Kit (P/N 6BSA000325)

6BTA000321

- (1) Terminal Box Kit (P/N 6BTA000323)
- (1) Jam Nut Kit (P/N 6BTA000318)
- (1) Oil Supply Tubing Kit (P/N 6BTA000326)

6BUA000322

- (1) Terminal Box Kit (P/N 6BUA000324)
- (1) Jam Nut Kit (P/N 6BTA000318)
- (1) Oil Supply Tubing Kit (P/N 6BUA000327)

6BVA000804

- (1) Terminal Box Kit (P/N 6BUA000324)
- (1) Jam Nut Kit (P/N 6BTA000318)
- (1) Oil Supply Tubing Kit (P/N 6BUA000803)

NOTE: One alternate Jam Nut Kit (P/N 6BUA000319) required for low voltage 06TU/06TV models.

9.3 Oil Accessories Kit

CARLYLE PART NUMBER	COMPRESSOR USAGE			
	TS	TT	TU	TV
6BTA000300	X	X	X	X

NOTE: One kit is required for each compressor.

Oil accessories kit contains following items:

- (1) Oil Filter (P/N 8BTB000312)
- (1) Oil Solenoid Valve (P/N 8BTB000313, coil not included)
- (1) Oil Line Check Valve (P/N 8BTB000314)
- (1) Oil Line Ball Valve (P/N EP71BA233)
- (1) Oil Supply/Filter Fittings Kit (P/N 6BTA000308, for supply oil line/oil filter connections)

9.4 Compressor Protection and Slide Valve Capacity Control Kits

PART NUMBER	DESCRIPTION	WEIGHT (LBS)	APPLICATION	COMPRESSOR USAGE
6BSB000929	High Temperature Controller Kit	5	R-134a	All Paragon MT/HT Models
6BSB000930	Low/Medium Temperature Controller	5	R404A, R-407A, R-407C, R-407F, R-507A	All Paragon LT Models
6BSB000931*	Pressure Transducer Kit	1	All	All Paragon Models
USB-L	Interface Cable	1	All	All Paragon Models

*Pressure Transducer Kit required for Applications that require a pressure-based control.

NOTES:

1. One Compressor Protection Module package required per compressor.
2. The interface cable is required to connect/configure the included module to a PC. The cable is also required for Field Service to read information from the module.

9.5 Service Valves and Service Flanges

9.5.1 Suction/Discharge Service Valve Package

Flanged Union, Solder Type, Cast Iron Valve Body

CARLYLE PART NUMBER	NOMINAL TUBE SIZE (in.)	COMPRESSOR USAGE		
		TS	TT	TU
06TT660064	2 ⁵ / ₈	D		
06TT660065	3 ¹ / ₈	S	D	
06TT660066	4 ¹ / ₈		S	D

LEGEND

D — Discharge
S — Suction

NOTE: In most Paragon medium temperature R-134a applications, the oil separator is connected directly to the compressor. Discharge service valves are not applicable in this type of design and a separate discharge line shutoff valve may be required to isolate the compressor.

9.5.2 Suction/Discharge Service Flange Package

The 4 and 8-bolt flange packages includes flange, flange adapter (when applicable), bolts, and gasket.

CARLYLE PART NUMBER	NOMINAL TUBE SIZE (in.)	COMPRESSOR USAGE			
		TS	TT	TU	TV
8BTB000286	2 ⁵ / ₈	D			
8BTB000287	3 ¹ / ₈	S	D		
8BTB000288	4 ¹ / ₈		S	D	
8BTB000289	5 (weld neck type)			S	D
8BTB000290	5 (socket type)			S	D
8BTB000291	5 (slip-on type)			S	D
8BTB000292	6 (weld neck type)				S
8BTB000293	6 (socket type)				S
8BTB000294	6 (slip-on type)				S

LEGEND

D — Discharge
S — Suction

9.6 Unloader, Motor Cooling Valve, and Oil Solenoid Control Coils

9.6.1 Unloader Control Solenoid Coils

CARLYLE PART NUMBER	VOLTAGE
EF19ZZ001	24-1-50/60
EF19ZZ002	120-1-50/60
EF19ZZ003	208/230-1-50/60
06DA509584	24 VDC

NOTES:

- Two coils of the correct voltage are required for each compressor.
- Unloader coils are not interchangeable with oil solenoid coils.

9.6.2 Oil Solenoid Valve Coils

CARLYLE PART NUMBER	VOLTAGE
8BTB000295	24-1-50/60
8BTB000297	120-1-50/60
8BTB000298	208/230-1-50/60
8BTB000296	24 VDC

NOTES:

- One coil of the correct voltage is required for each compressor.
- Unloader coils are not interchangeable with oil solenoid coils.
- Oil solenoid valve coils are also applied with Carlyle's motor cooling valves, shown in Section 9.9.2 Motor Cooling Valves.

9.7 Economizers

R-134a Only

CARLYLE PART NUMBER	COMPRESSOR USAGE							
	06TS*137	06TS*155	06TS*186	06TT*266	06TT*301	06TT*356	06TU*483	06TU*554
LL01SB040	X	X						
LL01SB042			X					
LL01SB046				X	X			
LL01SB050						X		
LL01SB054							X	
LL01SB056								X

* The fifth digit may be A, X, or W for all part numbers.

NOTES:

1. One economizer is required for each economized compressor.

2. Economizers shown are selected based on standard R-134a air conditioning-duty conditions. For other design conditions, economizer capacity will need to be verified.

R-404A / R-507A

COMPRESSOR MODEL	CARLYLE PART NUMBER
06TSR137	LL01SB042
06TSR155	
06TSR186	
06TTR266	LL01SB044
06TTR301	
06TTR356	
06TSM137	LL01SB042
06TSM155	
06TTM266	LI01SB046
06TTM301	

Economizer Flange Packages

CARLYLE PART NUMBER	COMPRESSOR USAGE	
	TS / TT	TU / TV
6BTA000309	X	
6BTA000310		X

NOTE: One economizer flange package required for each economized compressor.

Economizer Muffler

CARLYLE PART NUMBER	COMPRESSOR USAGE
8BTB000315	All Models (TS, TT, TU, TV)

NOTE: One economizer muffler package required for each economized R-134a compressor.

R-407A / R-407C / R-407F

COMPRESSOR MODEL	CARLYLE PART NUMBER
06TSR137	LL01SB042
06TSR155	
06TSR186	
06TTR266	
06TTR301	
06TTR356	
06TSM137	
06TSM155	
06TTM266	
06TTM301	

9.8 Motor Protection Devices

NOTE: Contact Application Engineering for appropriate motor protection devices.

9.9 Oil Coolers/Liquid Injection Valves

9.9.1 Air-Cooled Oil Coolers

CARLYLE PART NUMBER	COMPRESSOR USAGE			
	TS	TT	TU	TV
KH51ZZ181	X	X	X	X
KH51ZZ182	X	X	X	X
KH51ZZ183	X	X	X	X
KH51ZZ184	X	X	X	X

NOTE: All low/medium temperature Paragon compressors require oil cooling. Contact Carlyle Application Engineering for sizing information.

Oils

PART NUMBER	USAGE	QUANTITY
SOLEST170-1G	Low/Medium Temperature — 06TSR, 06TTR	1-Gallon Container
SOLEST170-5G	Low/Medium Temperature — 06TSR, 06TTR	5-Gallon Container
P903-2301*	Medium/High Temperature — 06TSA, 06TTA, 06TUA, 06TVA	1-Gallon Container
P903-2305	Medium/High Temperature — 06TSA, 06TTA, 06TUA, 06TVA	5-Gallon Container

* Minimum order is quantity of 4, 1-gallon containers.

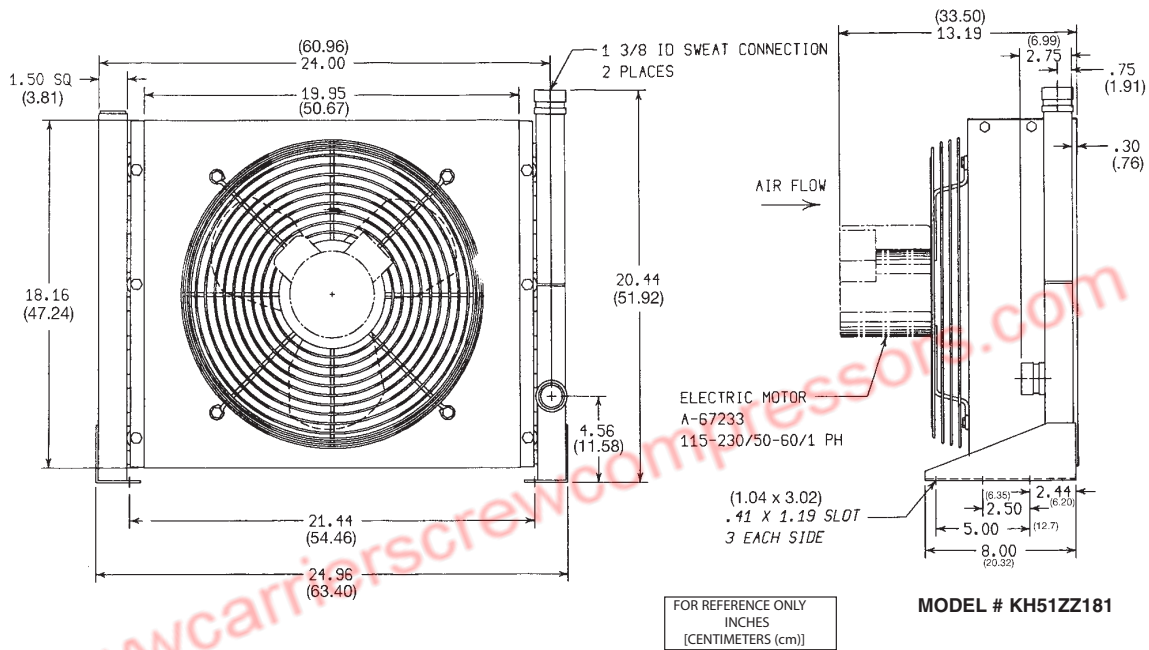

OIL INLET AT BOTTOM – OIL OUTLET AT TOP; ALL MODELS

Electrical Specifications: All Models

Voltage: 115/230V 50/60Hz

Amperage*: 3.2/1.6 Amps Full Load 60Hz

2.8/1.4 Amps Full Load 50Hz

*Amperage ratings are per motor

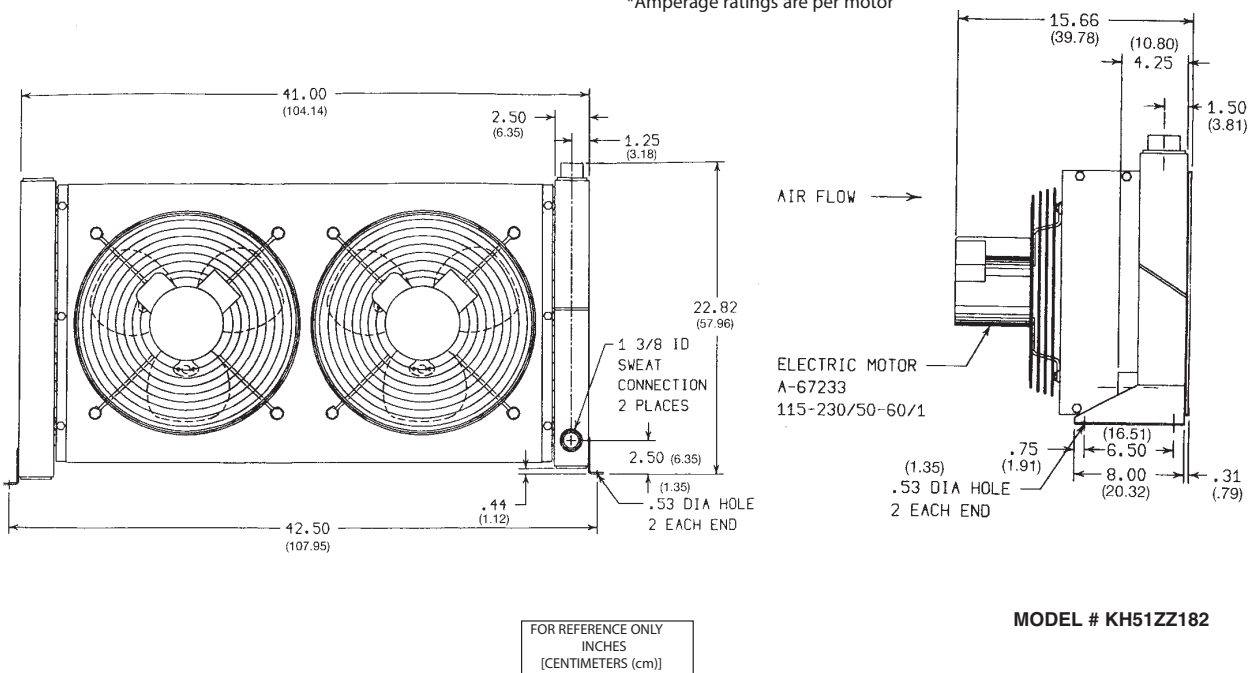
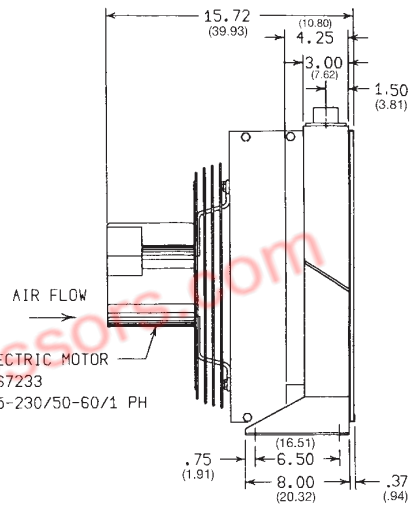
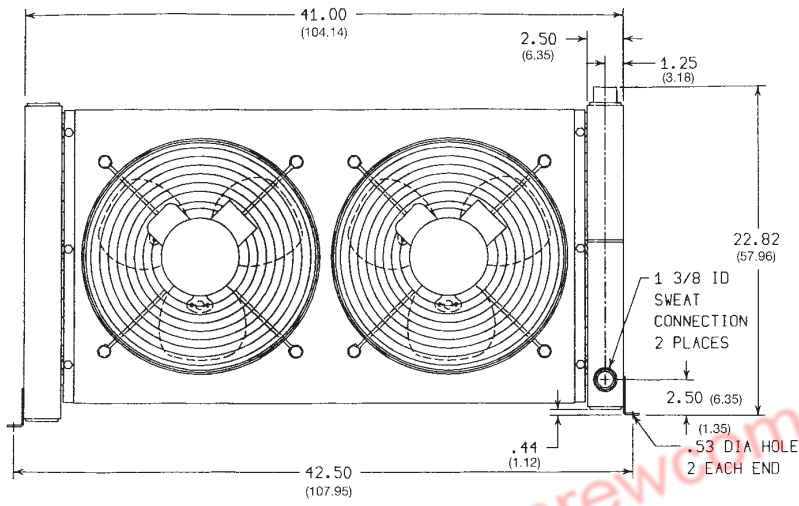

Fig. 31 — Oil Coolers



FOR REFERENCE ONLY
INCHES
[CENTIMETERS (cm)]

MODEL # KH51ZZ183

OIL INLET AT BOTTOM – OIL OUTLET AT TOP; ALL MODELS

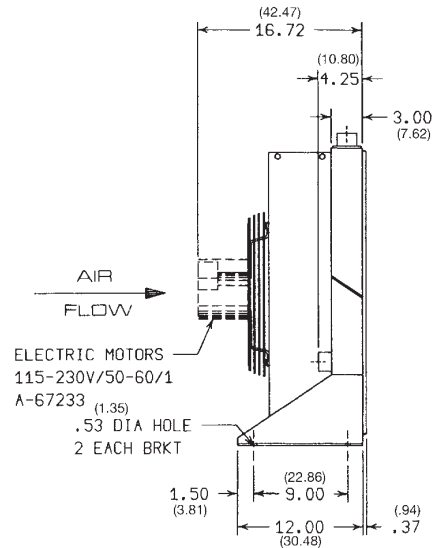
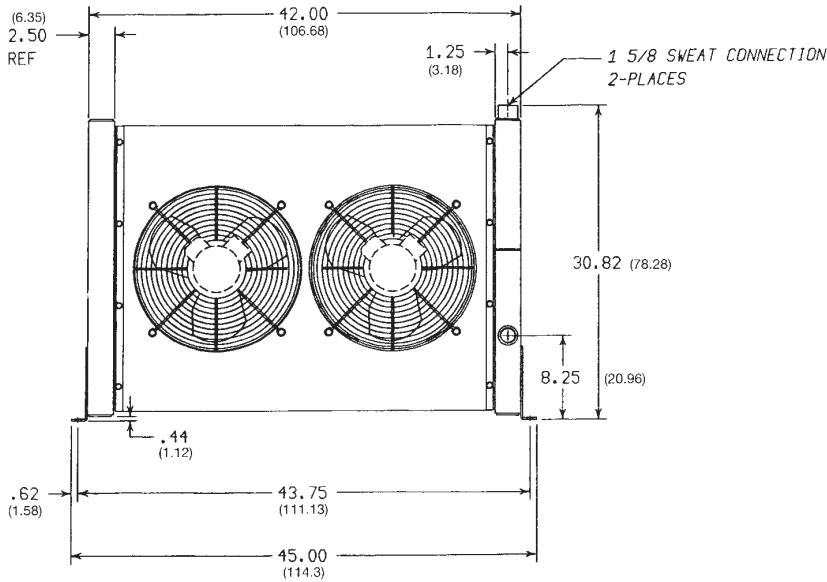

FOR REFERENCE ONLY
INCHES
[CENTIMETERS (cm)]

MODEL # KH51ZZ184

Fig. 31 — Oil Coolers (cont)

9.9.2 Motor Cooling Valves

CARLYLE PART NUMBER	DANFOSS PART NUMBER EVRP SIZE	COMPRESSOR USAGE			
		TS	TT	TU	TV
EF28BZ005	1.0	X	X	X	X
EF28BZ007	1.4	X	X	X	X

NOTES:

1. Motor cooling valves inject liquid into the suction line. Contact Carlyle Application Engineering for sizing information.
2. Motor cooling valves require one coil of the appropriate voltage.
3. See Section 9.6.2 Oil Solenoid Valve Coils.

9.9.3 De-Superheating Valves

CARLYLE PART NUMBER	SIZE (TON)	COMPRESSOR USAGE			
		TS	TT	TU	TV
EA02ZD001	1	X	X	X	X
EA02ZD002	1.5	X	X	X	X
EA02ZD030	2	X	X	X	X
EA02ZD050	3	X	X	X	X
EA02ZD100	5	X	X	X	X

NOTE: De-superheating valves inject liquid into the economizer line or the economizer inlet port. Contact Carlyle Application Engineering for sizing information.

10.0 Packaging and Storage Requirements

10.1 Packaging

Packaging for the Paragon screw compressor utilizes a wooden pallet and shrink-wrap plastic.

10.2 Shipping

All compressors that are shipped within the U.S. or internationally will be unstacked (single layer).

10.3 Storage

Although the Paragon compressors are painted to meet the 500 hours salt spray requirement, it is preferable to store the compressors indoors where they are shielded from the weather. Outdoor storage is permissible as long as temperatures stay within a temperature range of 40 F to 176 F (40 C to 80 C).

10.4 Weights and Dimensions

Compressor weights and dimensions are shown in Table 19. See also Fig. 32.

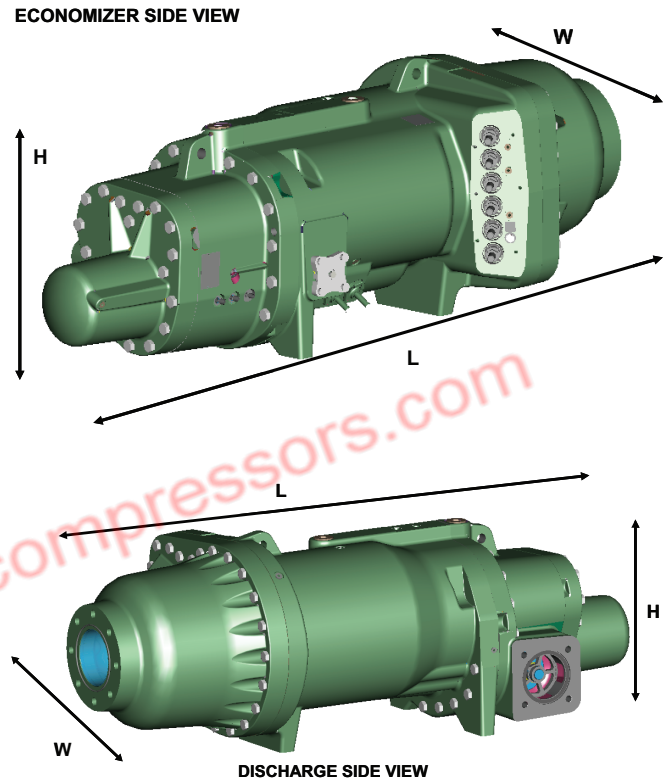

Fig. 32 — Compressor Dimensions

Table 19: Basic Compressor Weight and Dimensions (Without Electrical Box and Oil Separator)

BASIC COMPRESSOR WEIGHT AND DIMENSIONS (WITHOUT ELECTRICAL BOX AND OIL SEPARATOR)								
MODEL	WEIGHT		DIMENSIONS					
			HEIGHT 'H'		WIDTH 'W'		LENGTH 'L'	
	lb	kg	in.	mm	in.	mm	in.	mm
06TS-137---	814	369	16	412	19	480	41	1029
06TS-155---	830	376	16	412	19	480	41	1047
06TS-186---	867	393	16	412	19	480	43	1091
06TT-266---	1352	613	19	481	21	536	50	1276
06TT-301---	1389	630	19	481	21	536	51	1299
06TT-356---	1460	662	19	481	21	536	53	1347
06TU-483---	2018	915	21	531	23	591	58	1466
06TU-554---	2108	956	21	531	23	591	60	1514
06TV-680---	2585	1173	23	583	24	608	68	1731
06TV-753---	2608	1183	23	583	24	608	68	1731
06TV-819---	2626	1191	23	583	24	608	68	1731

10.5 Compressor/Compact Oil Separator Assembly

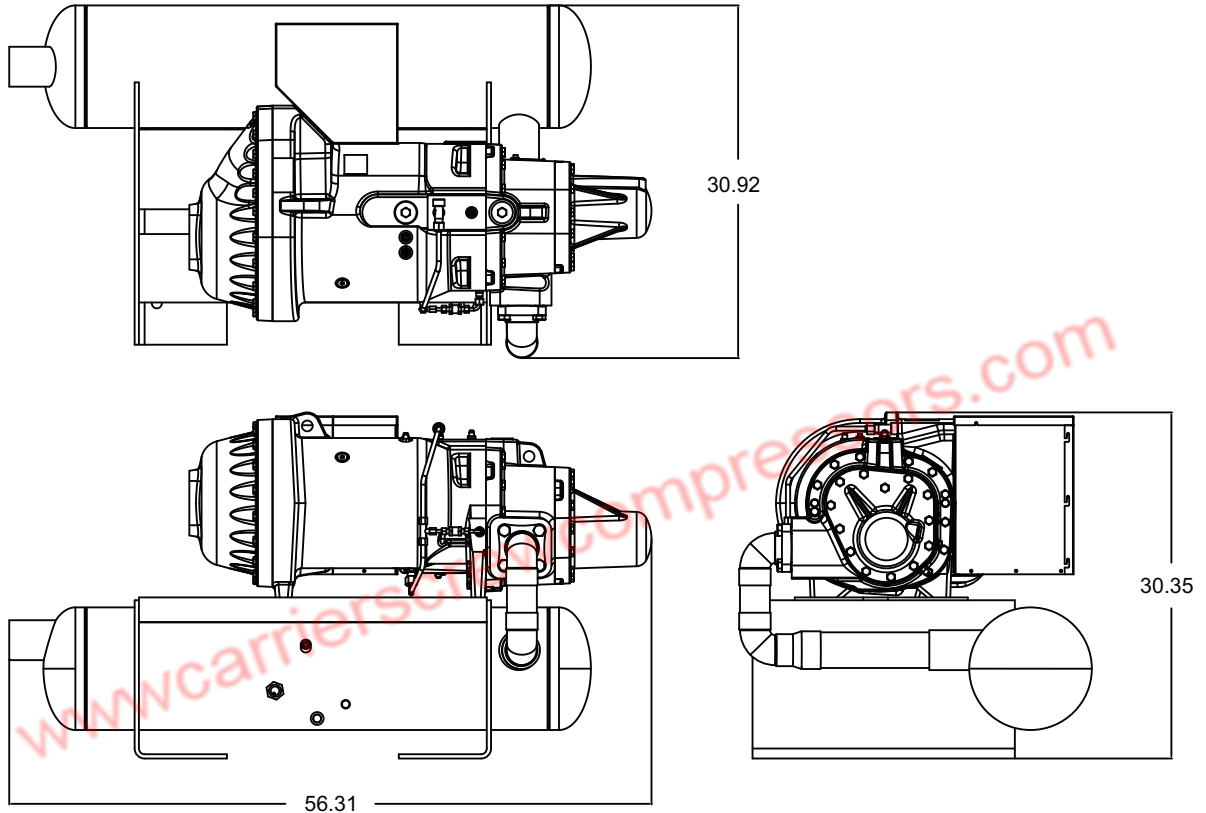

Fig. 33 — 06TSA137 Assembly Drawing

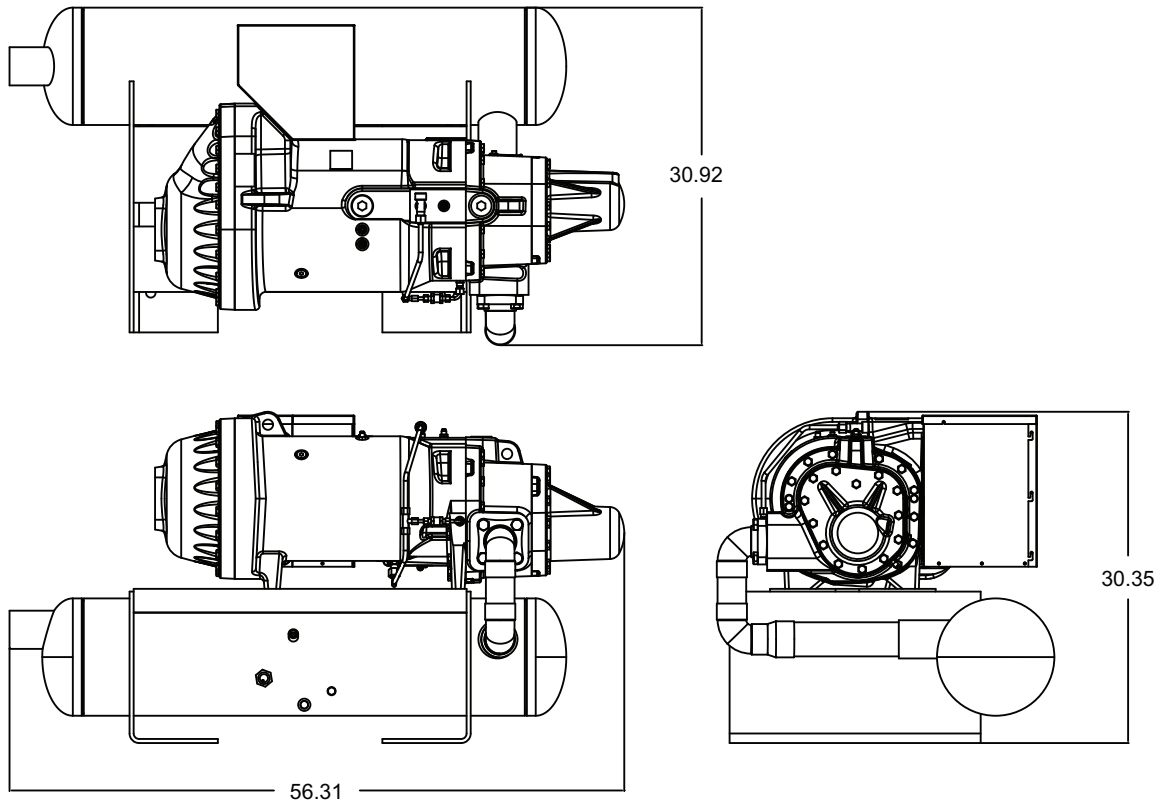

Fig. 34 — 06TSA155 Assembly Drawing

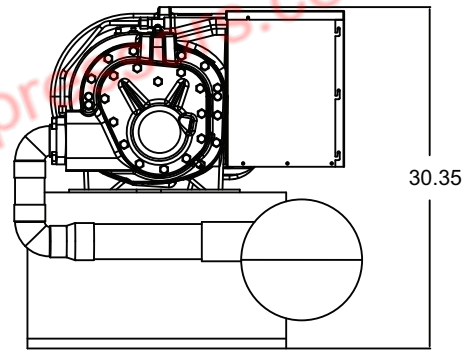
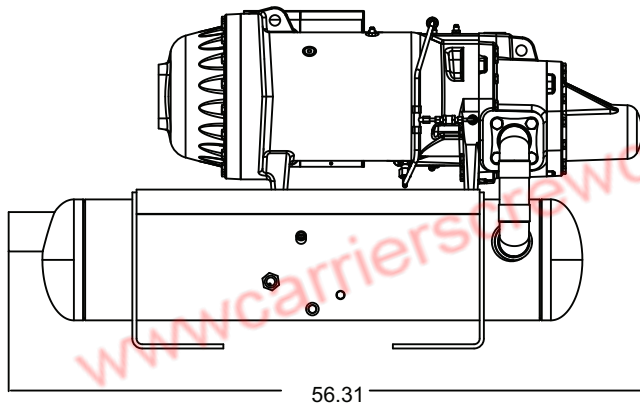
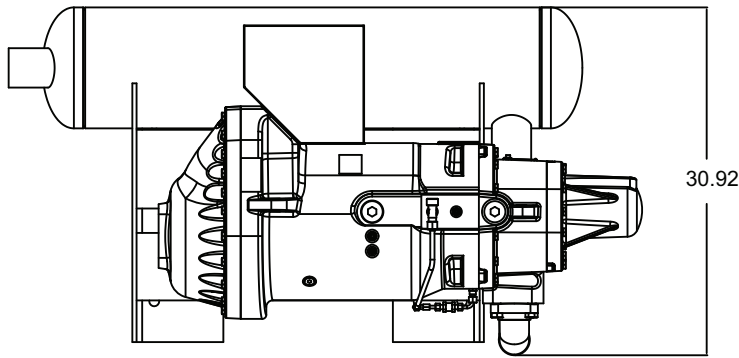

Fig. 35 — 06TSA186 Assembly Drawing

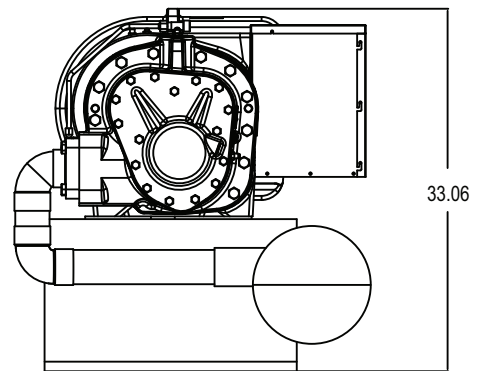
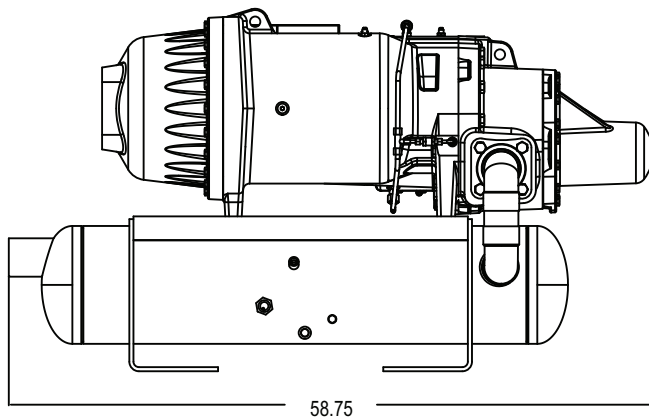
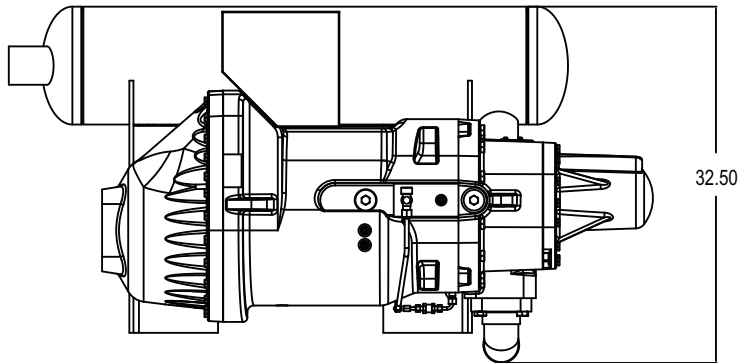

Fig. 36 — 06TTA266 Assembly Drawing

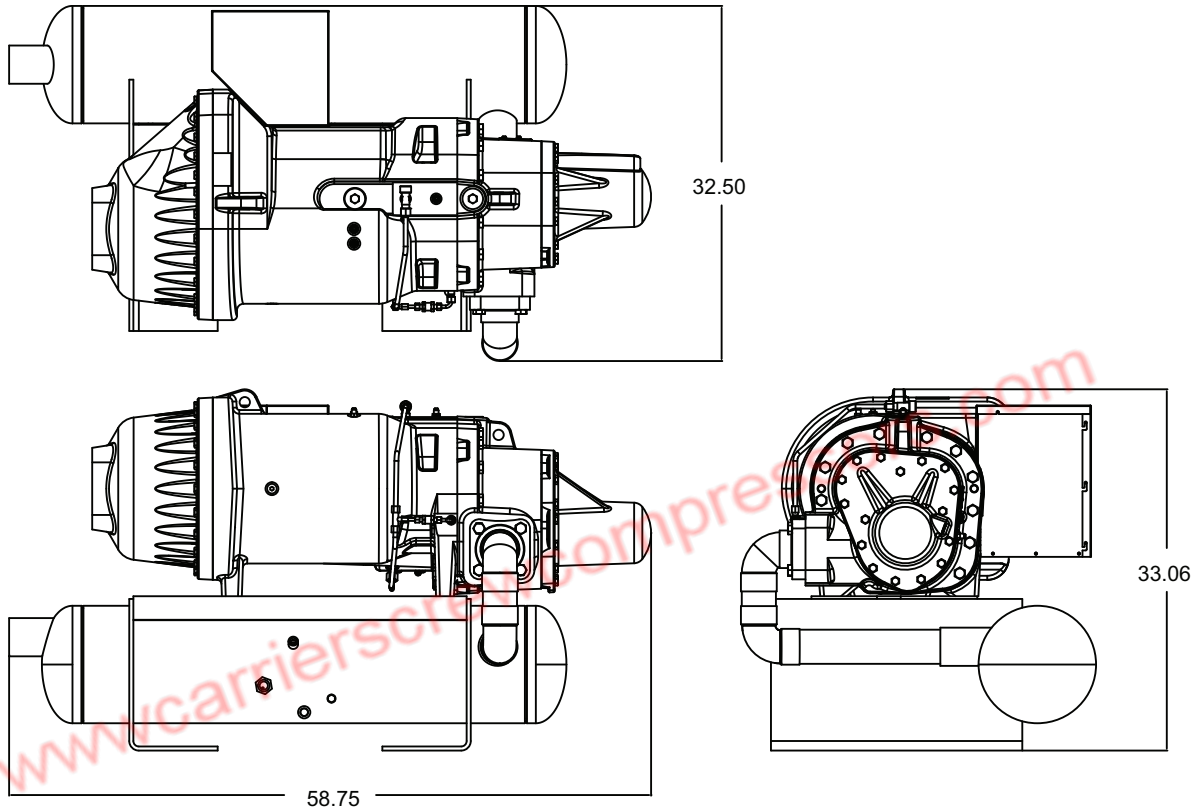

Fig. 37 — 06TTA301 Assembly Drawing

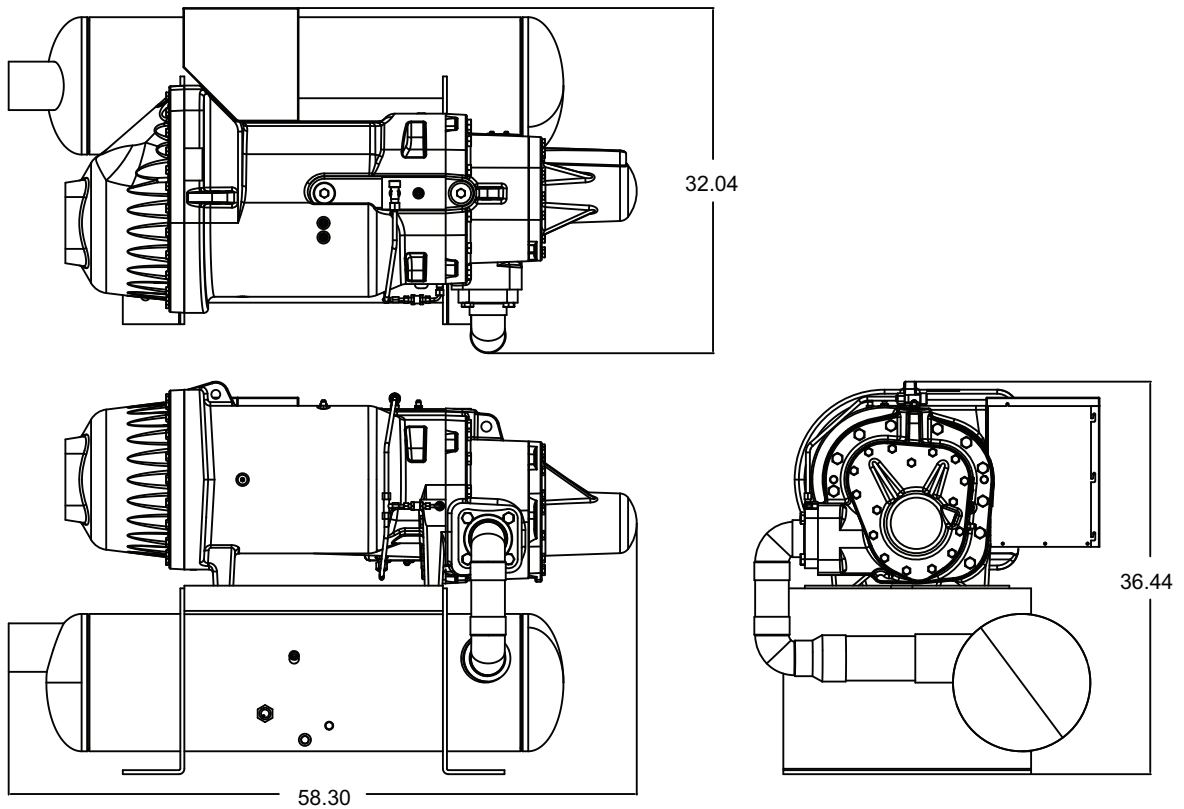

Fig. 38 — 06TTA356 Assembly Drawing

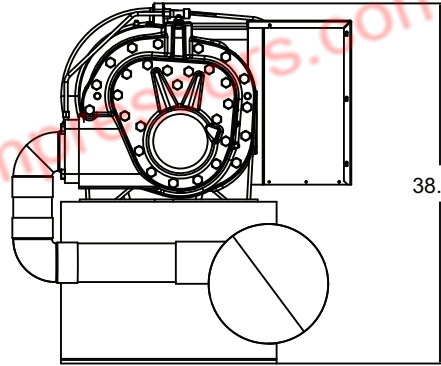
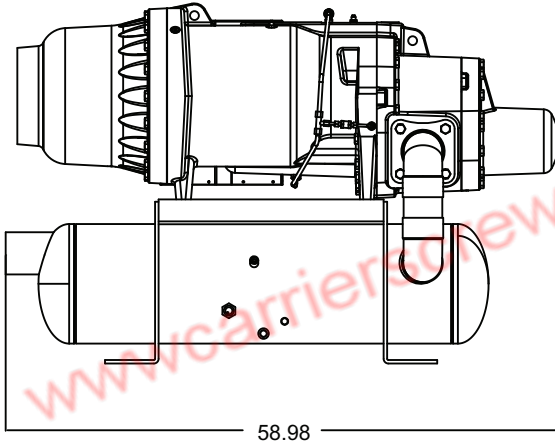
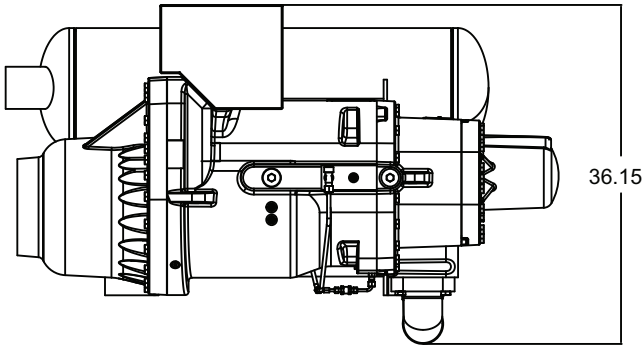

Fig. 39 — 06TUA483 Assembly Drawing

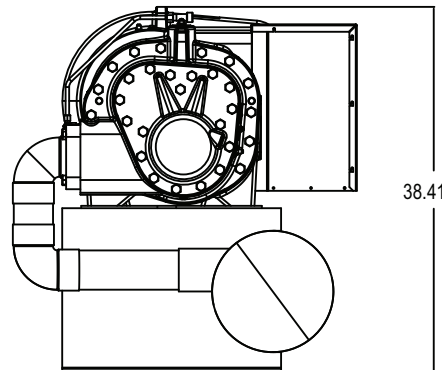
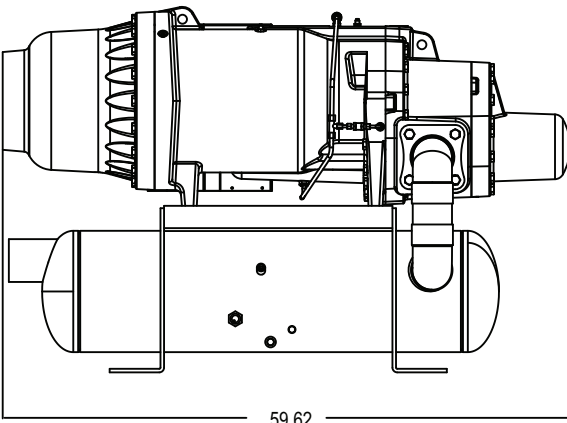
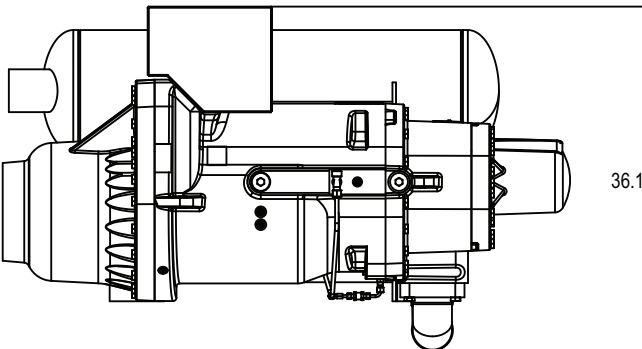

Fig. 40 — 06TUA554 Assembly Drawing